

CAMBRIDGE

مرجع زبان ایرانیان

www.irLanguage.com

SUPER MINDS

Workbook Starter

Herbert Puchta

Günter Gerngross

Peter Lewis-Jones

مرجع آموزش زبان ایرانیان
www.irLanguage.com

Herbert Puchta

Günter Gerngross

Peter Lewis-Jones

Super Minds

Workbook Starter

●	Hello	2	6	On the farm	58
1	My classroom	8	7	I'm hungry!	68
2	My family	18	8	All aboard!	78
3	My face	28	9	Party clothes	88
4	Toys	38		Cut-outs	99
5	My house	48			

این مجموعه با لوگوی مرجع زبان ایرانیان
به صورت نشر برخط و حامل به ثبت رسیده است.

کپی برداری از آن خلاف قانون، شرع و اخلاق است و شامل پیگرد خواهد شد.

Hello

1 Match and say the names.

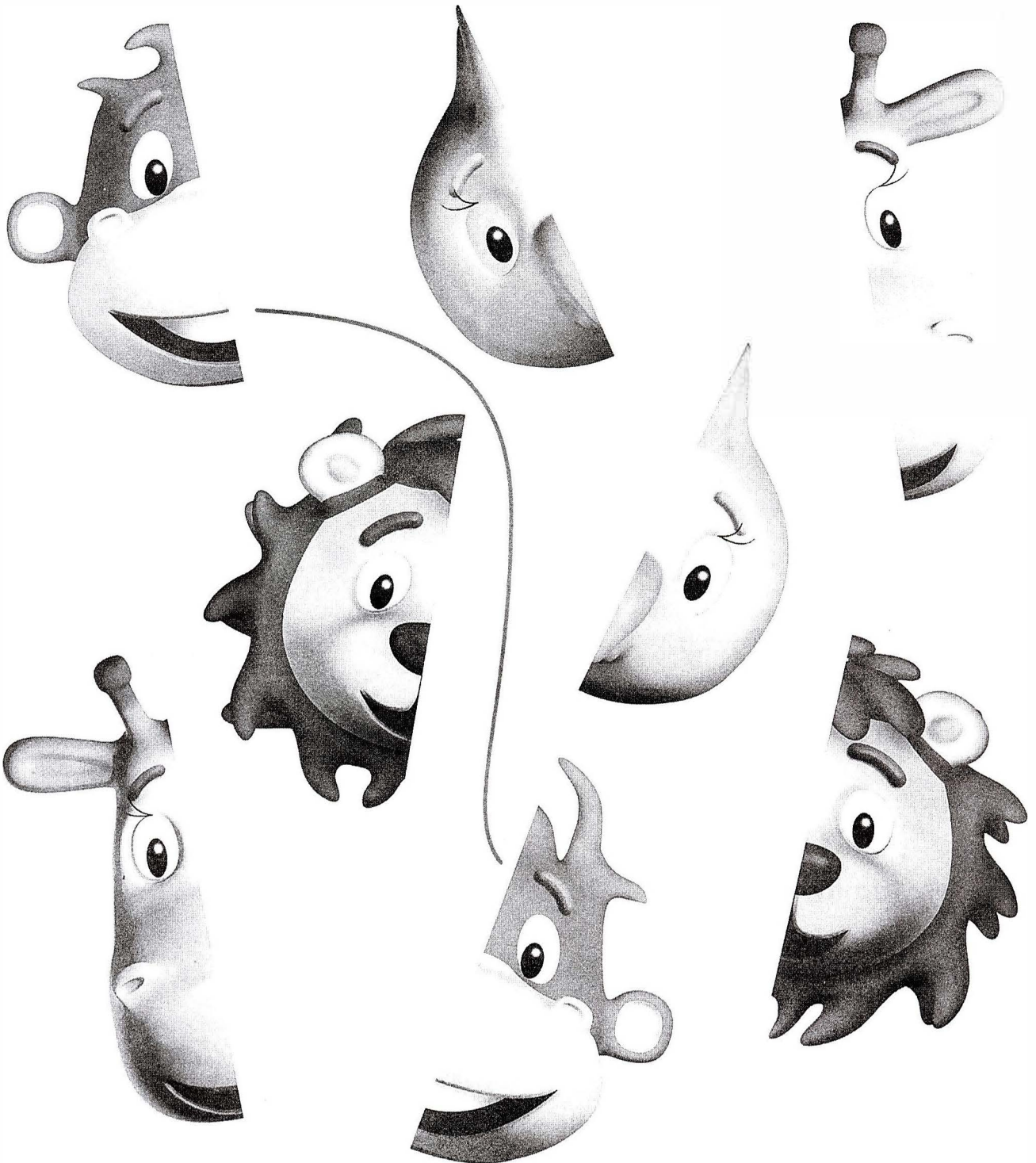

2 Practice

1 Trace and match.

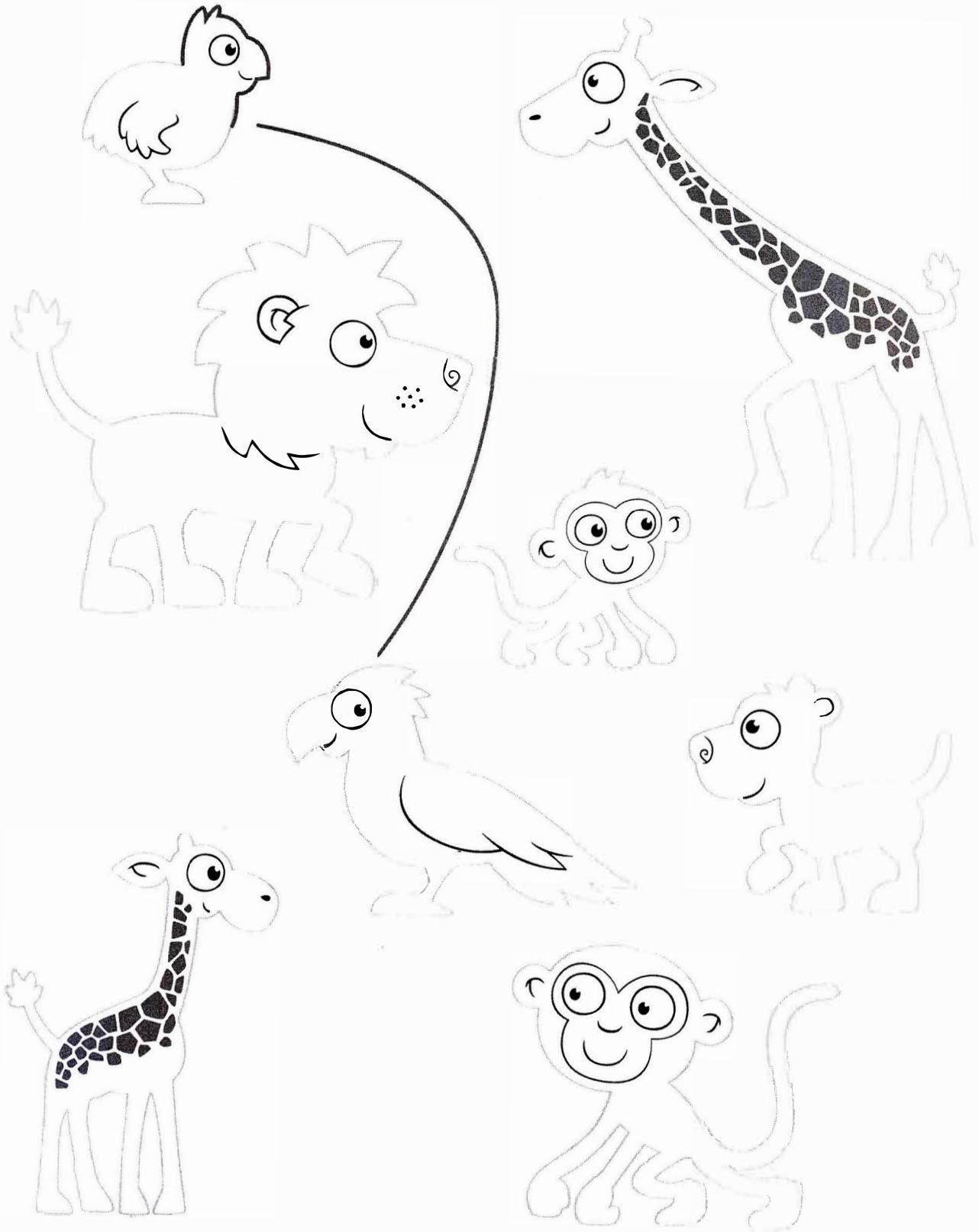



Listen and trace.

1

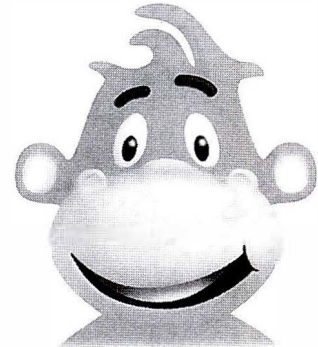

2

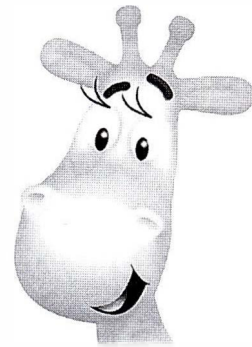
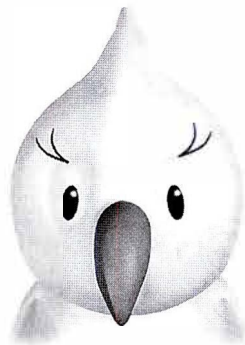

3

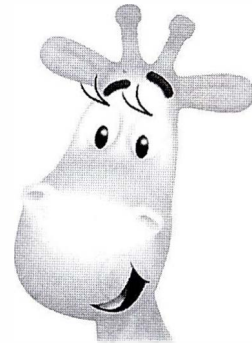
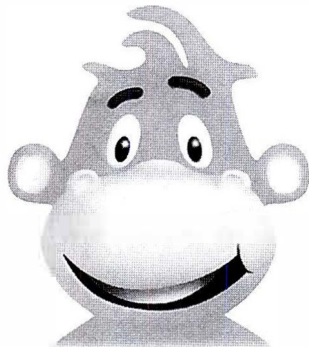

4

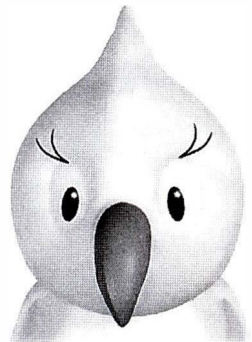

4

I'm (Mike, Leo, Gina, Polly).



Listen and colour.

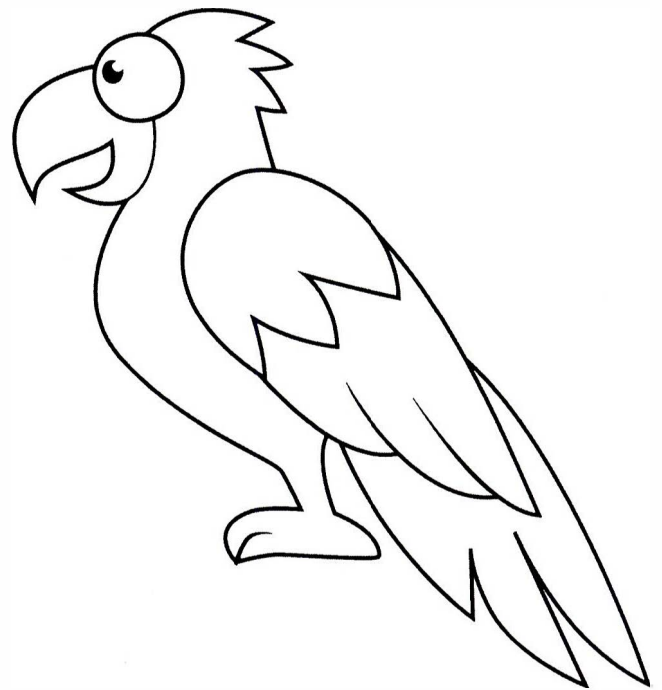
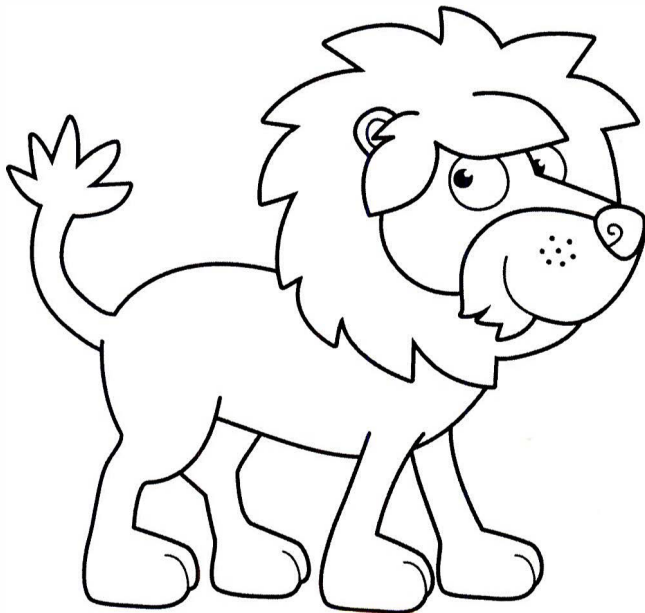
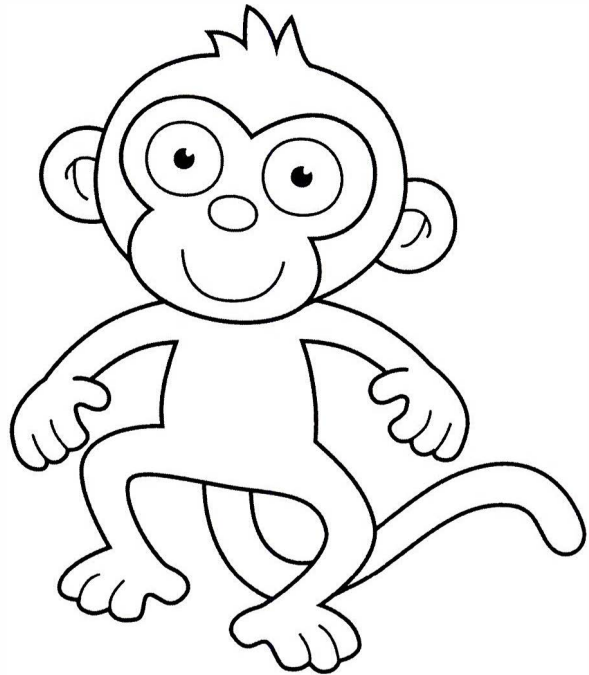
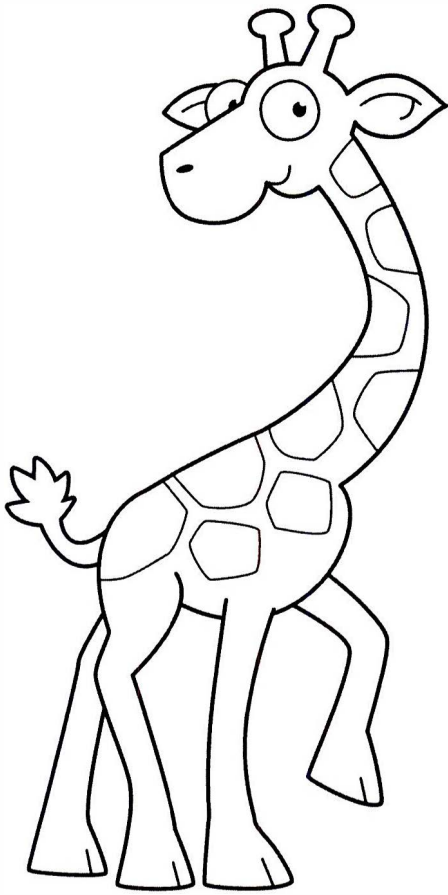

red, blue, green, orange, purple, yellow

1

Think! Look and colour.

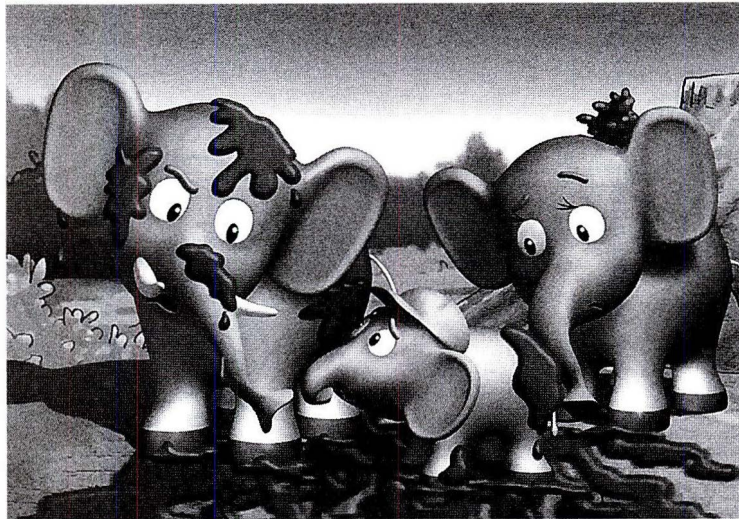

1



2

www.irLanguage.com

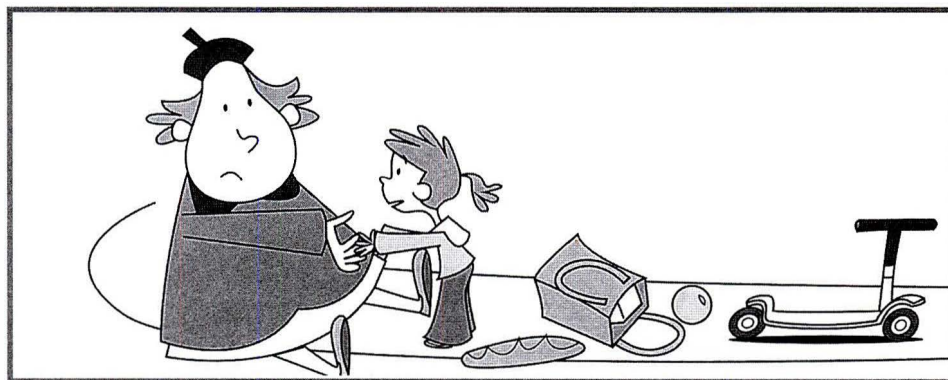

6

Value: saying *Sorry*

1 Colour. Say the words.

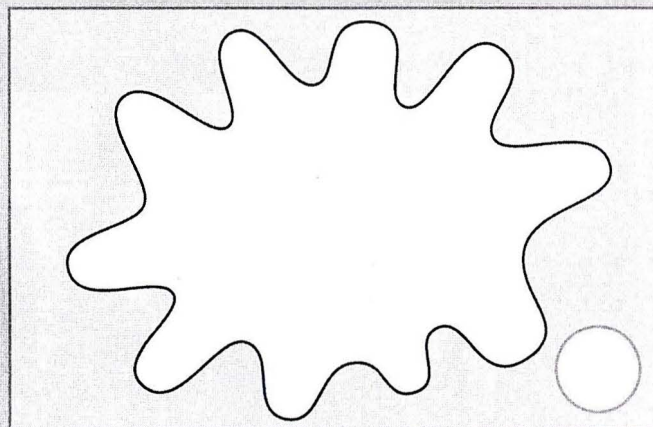
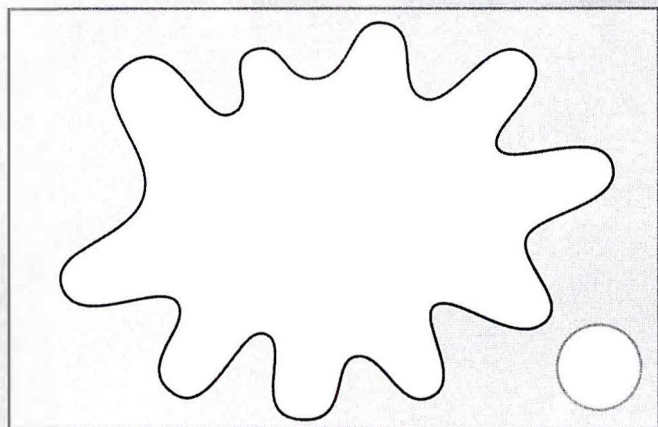
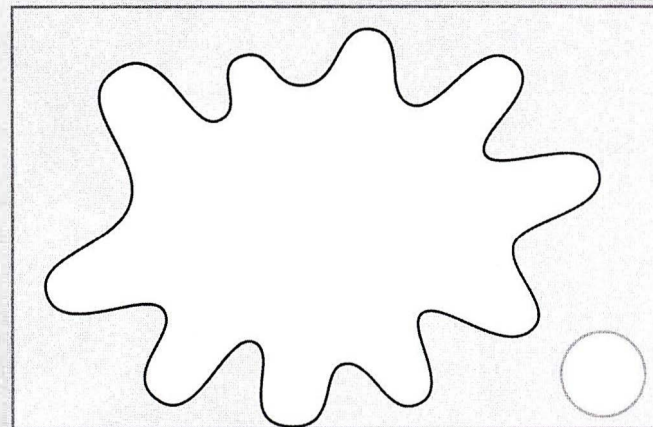
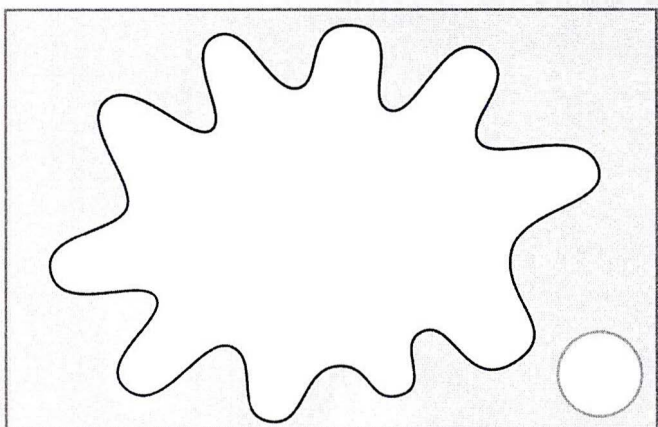
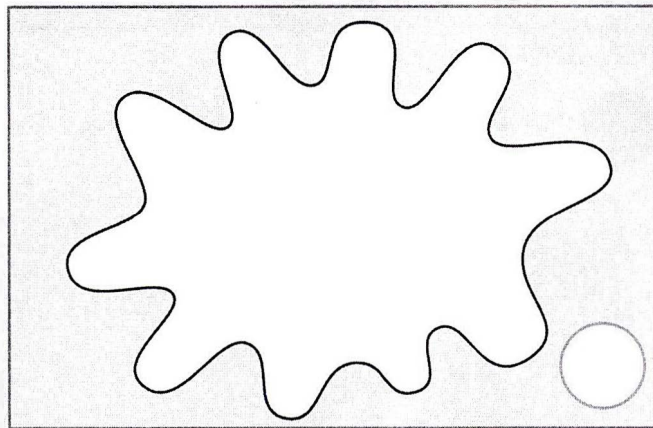
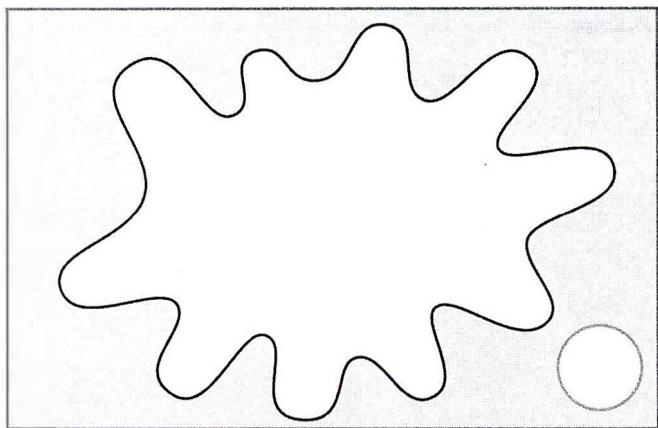

2 Draw faces. 😊 😐 😞

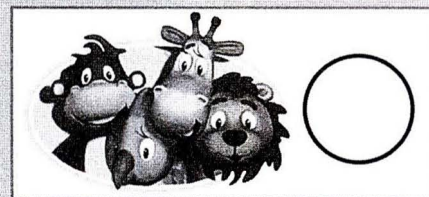
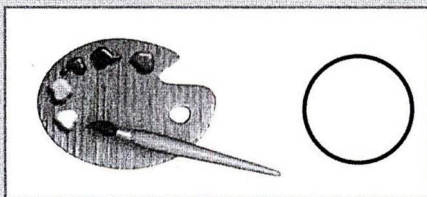
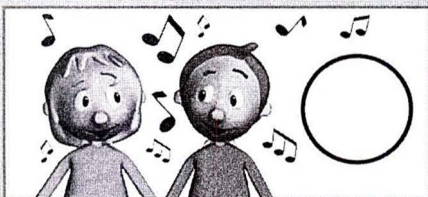

1

My classroom

1

Find and colour.



8

pencil, chair, bag, rubber, book, desk

1 CD1
14 Listen and circle.

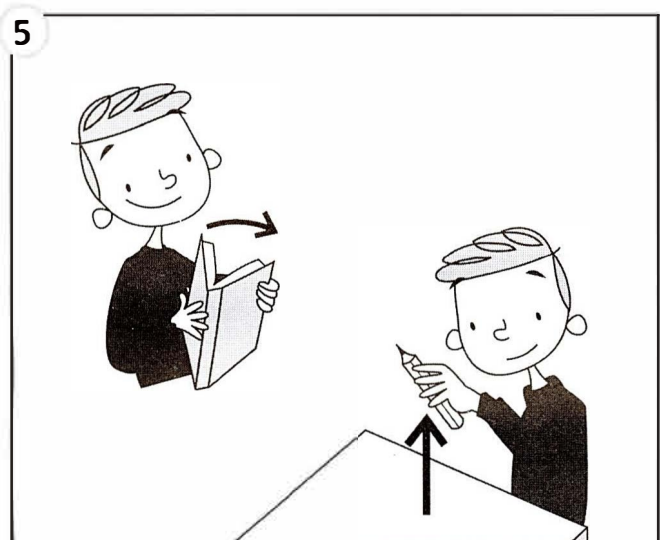
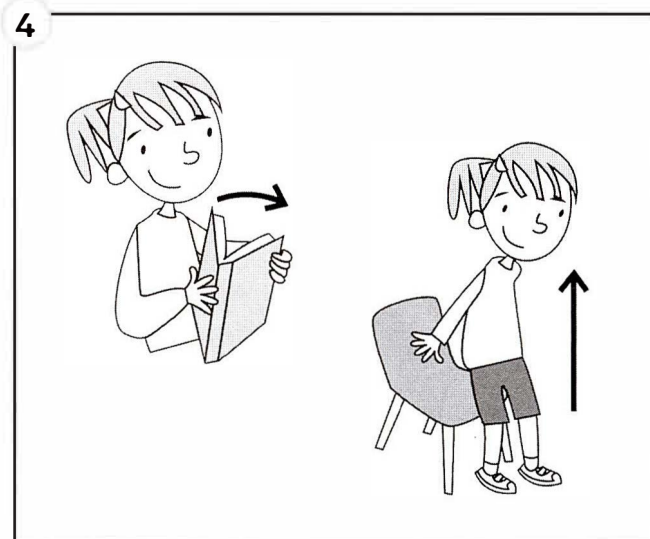
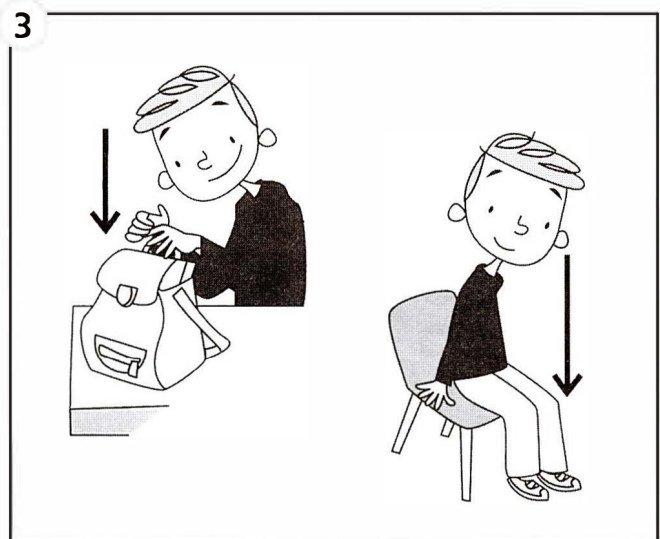
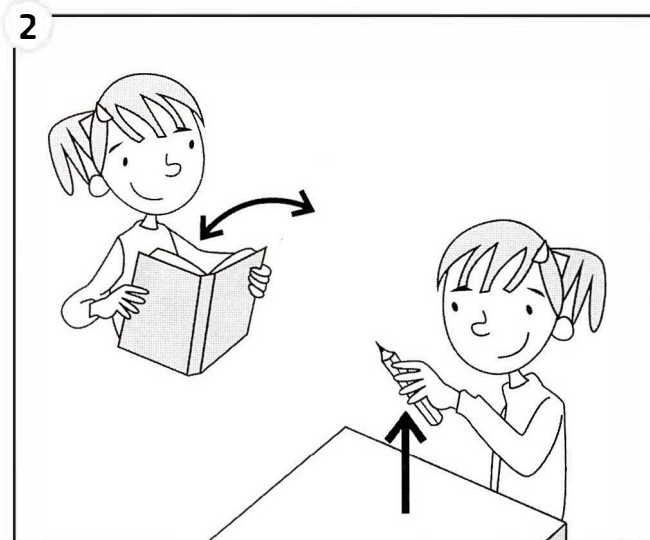
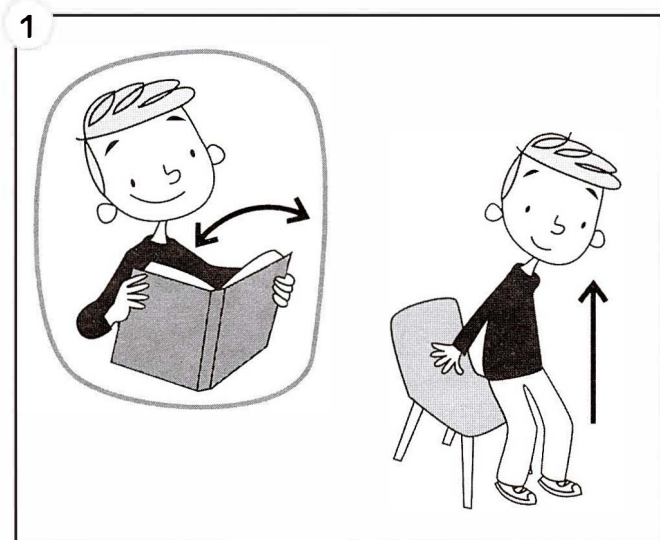

1 Draw and colour.

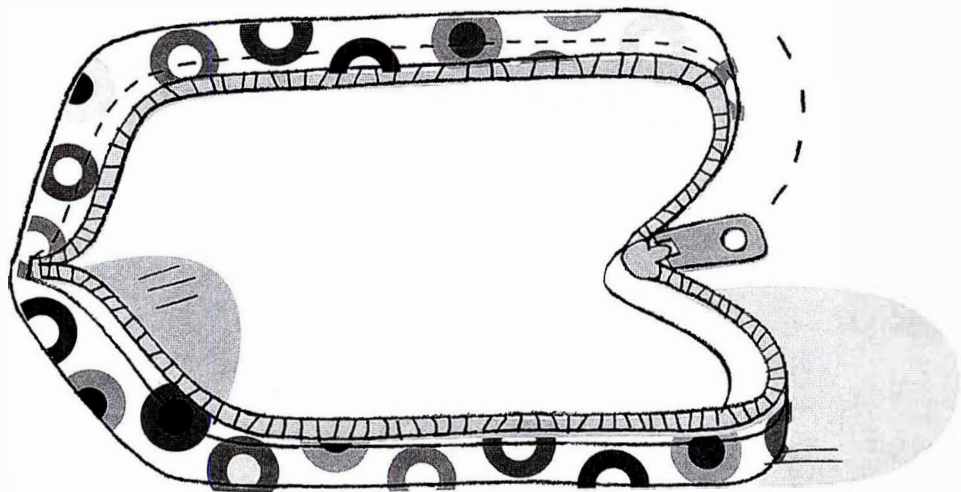
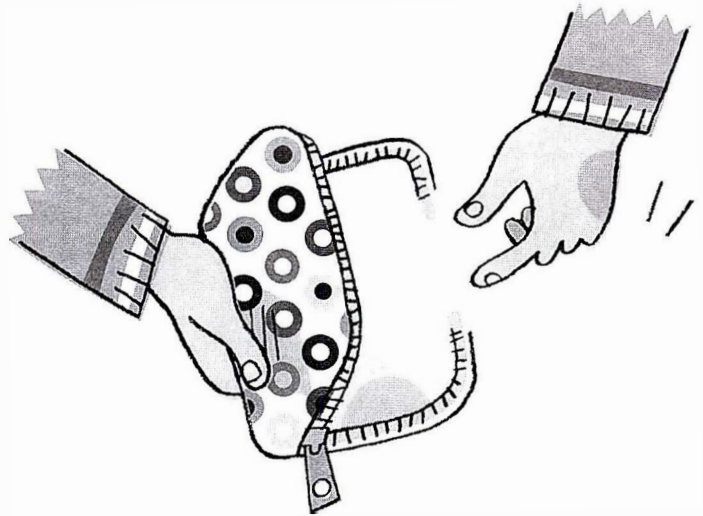
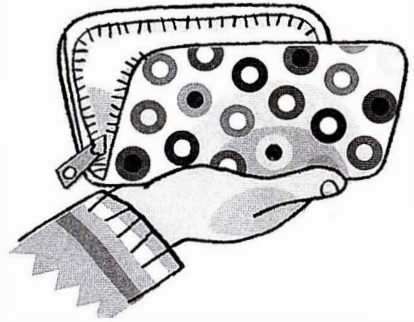
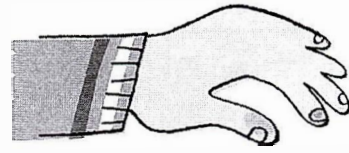

1 Think! Count and match.

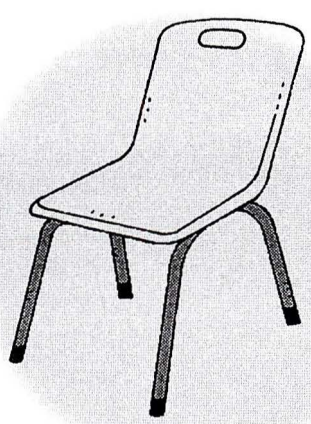
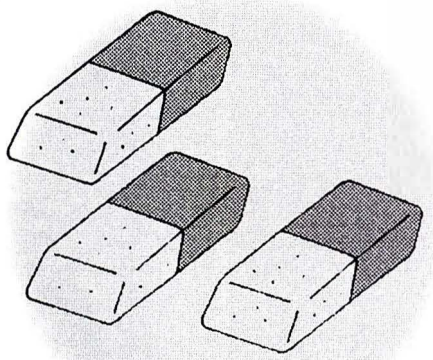
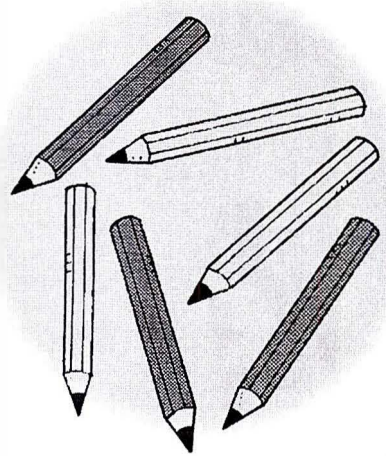
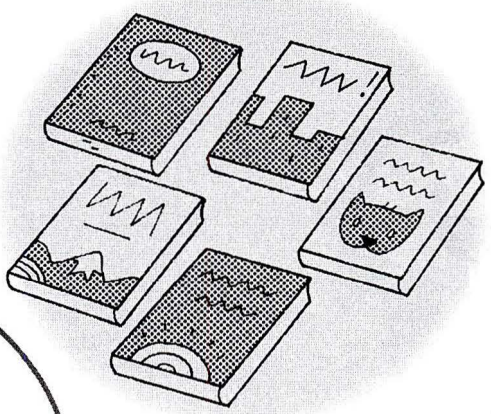
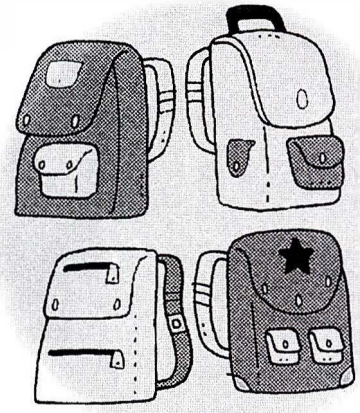
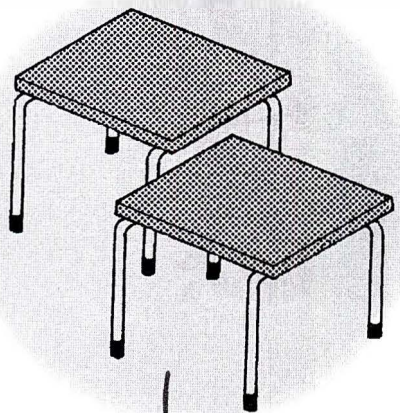

1 2 3 4 5 6

Listen and trace.

1

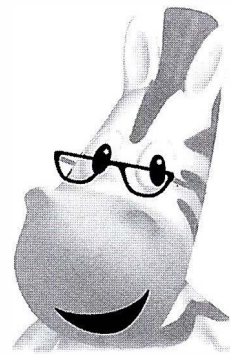

2

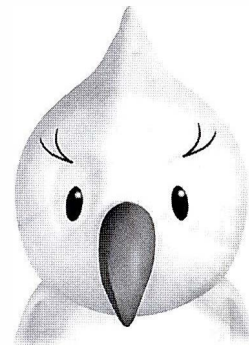

3

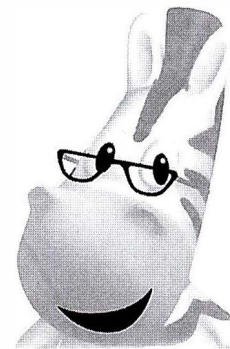
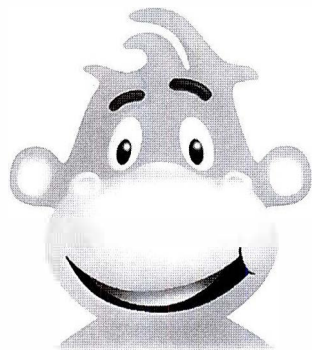

4

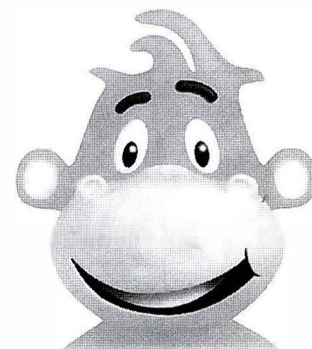

1 Think! Look and colour.

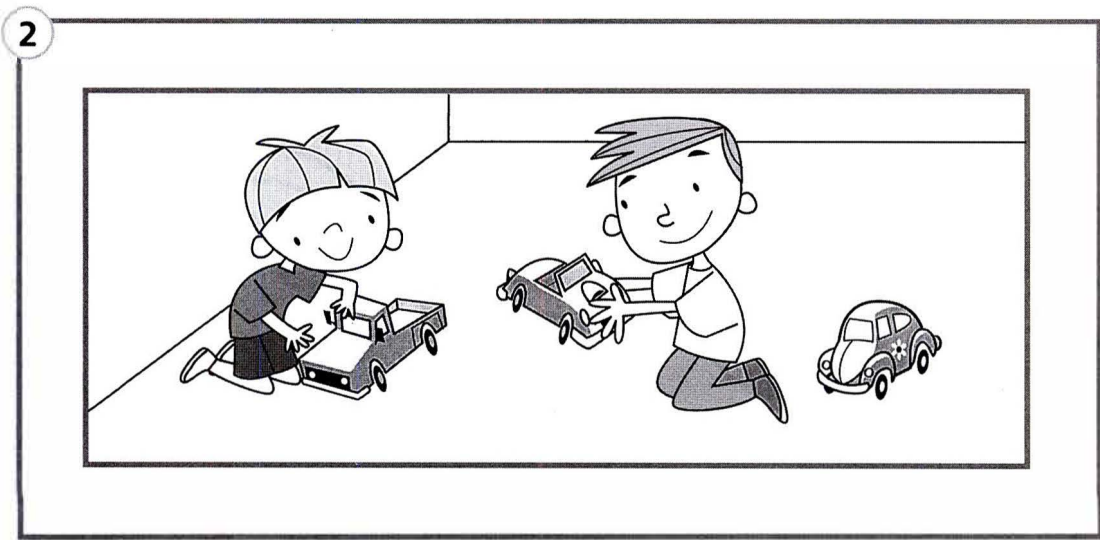
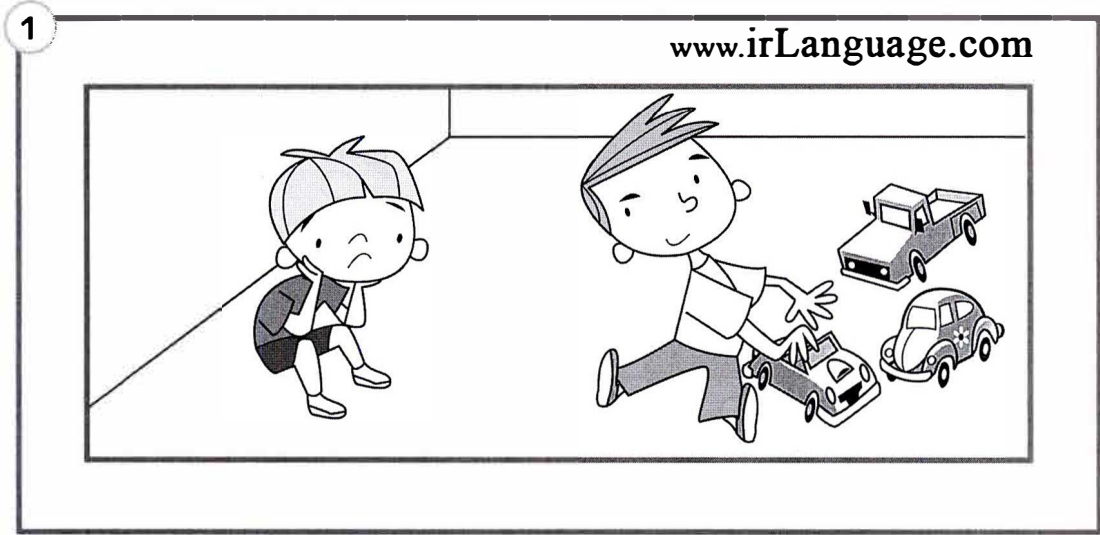



1 Listen and colour. Colour to match.

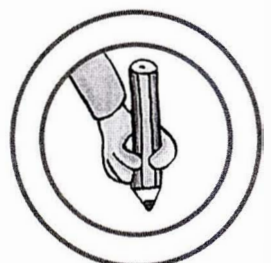
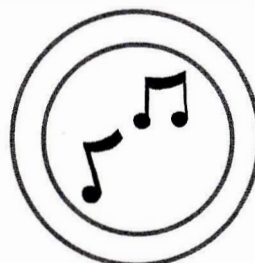
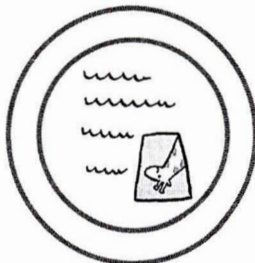
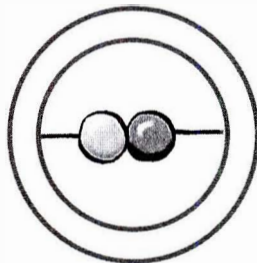
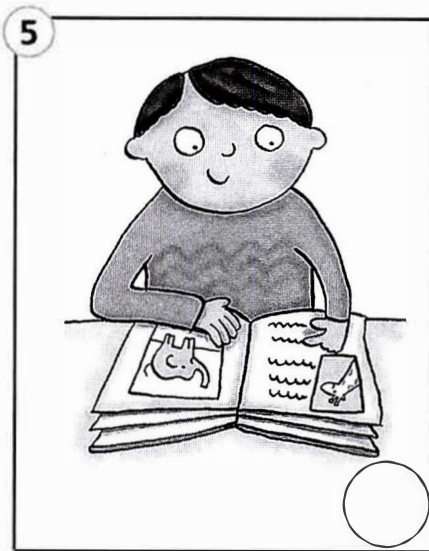
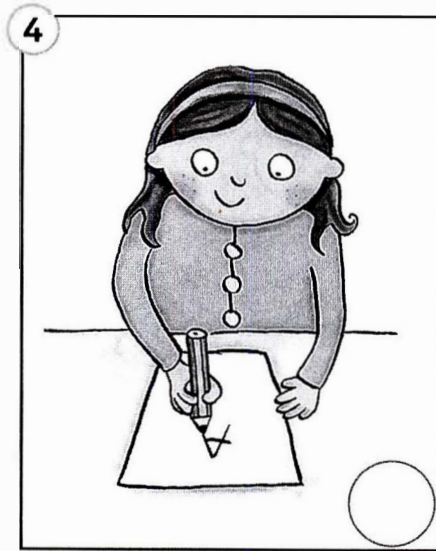

1 Look and circle.

1

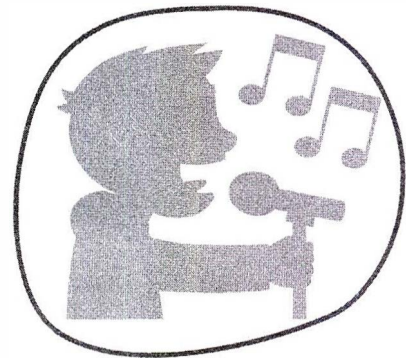

2

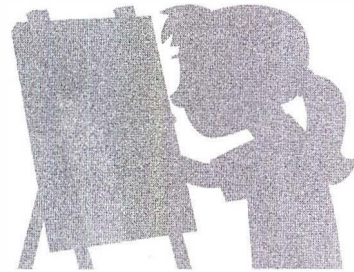
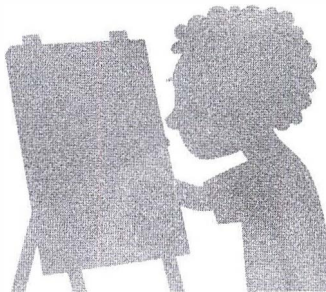
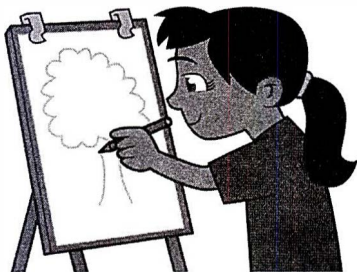

3



4

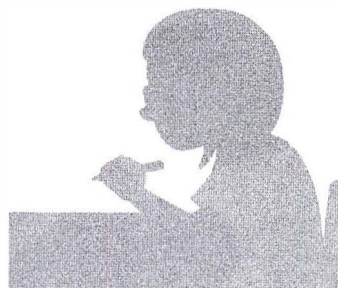

5

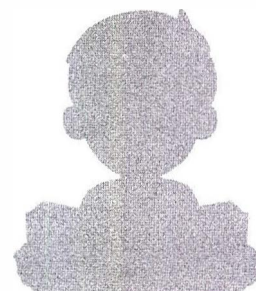
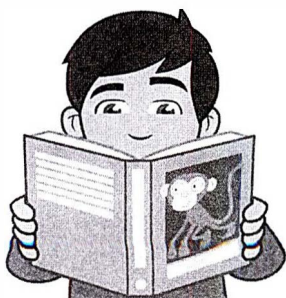

1 Say the words. Colour the circles.

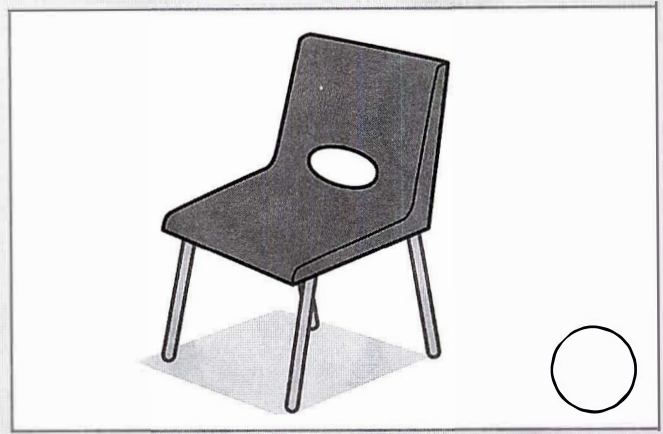
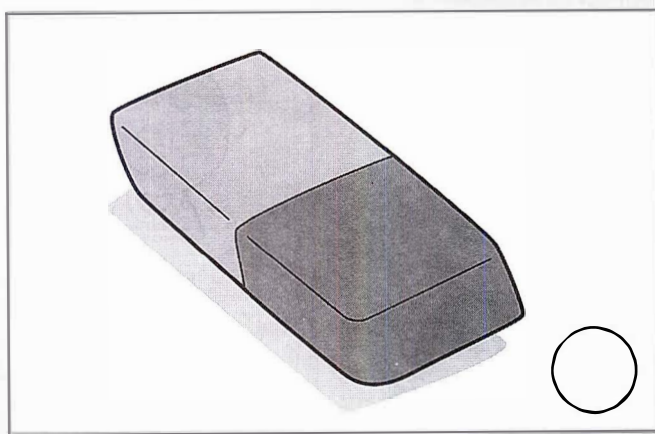
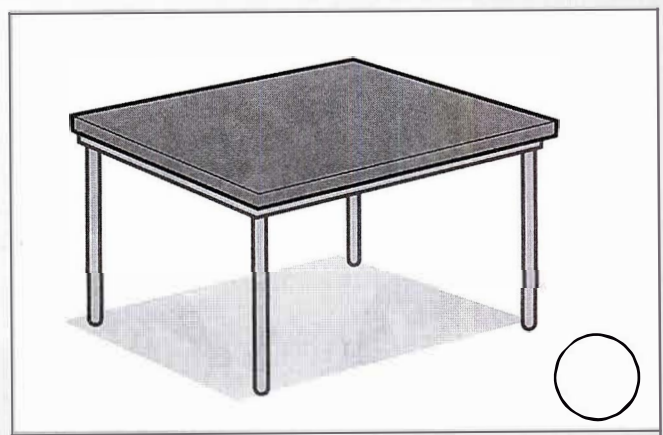
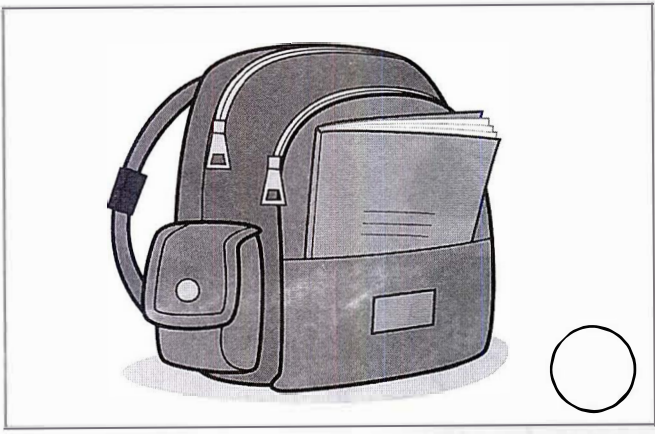
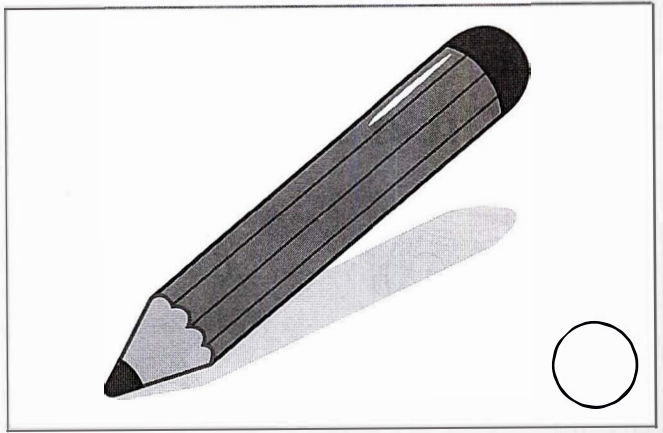
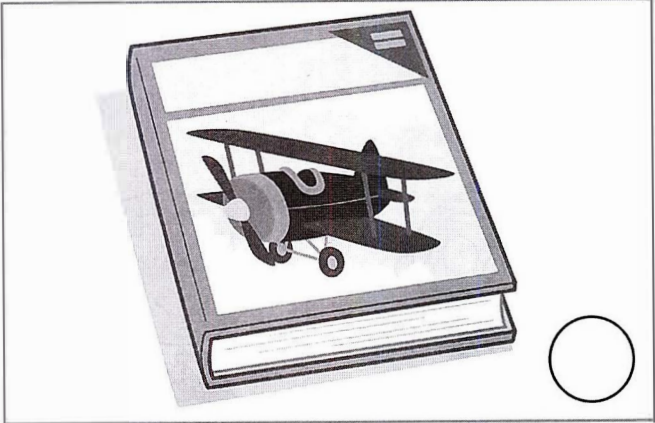

2 Draw faces. 😊 😐 😞

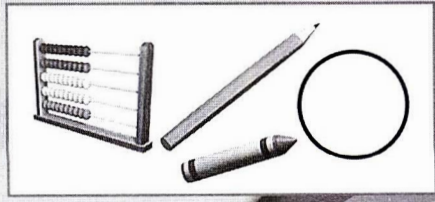
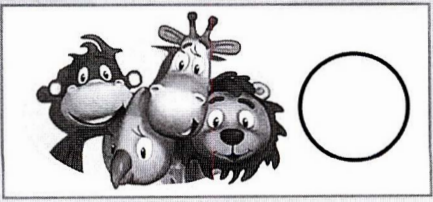
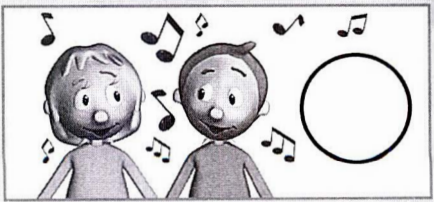

2

My family

1 Circle and say the words.

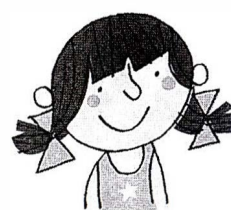
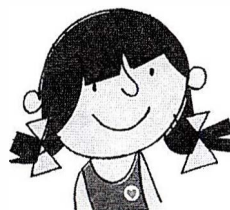
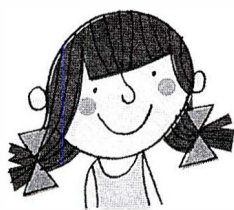
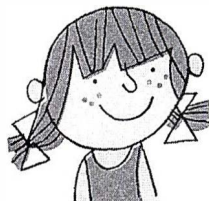
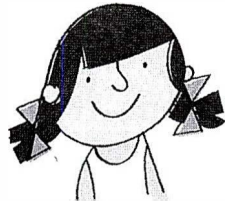
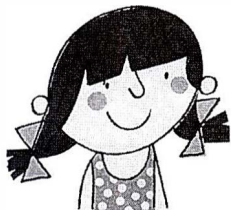
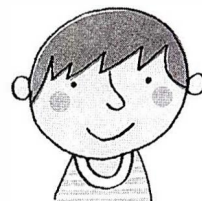
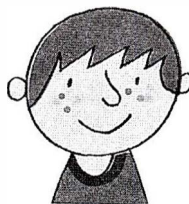
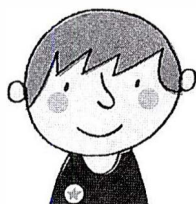
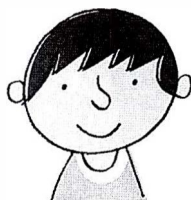
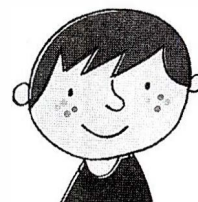
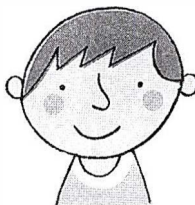
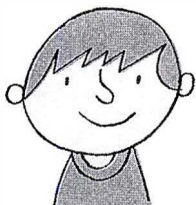
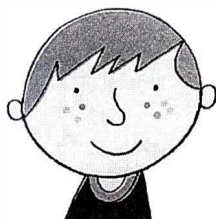
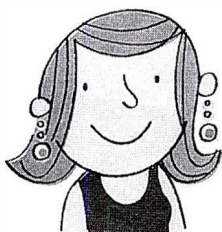
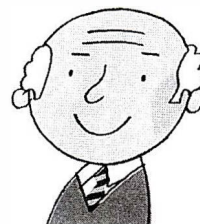
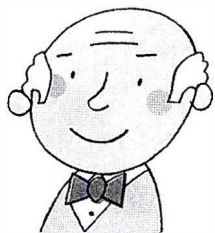

1 CD1
26

Listen and circle.

1

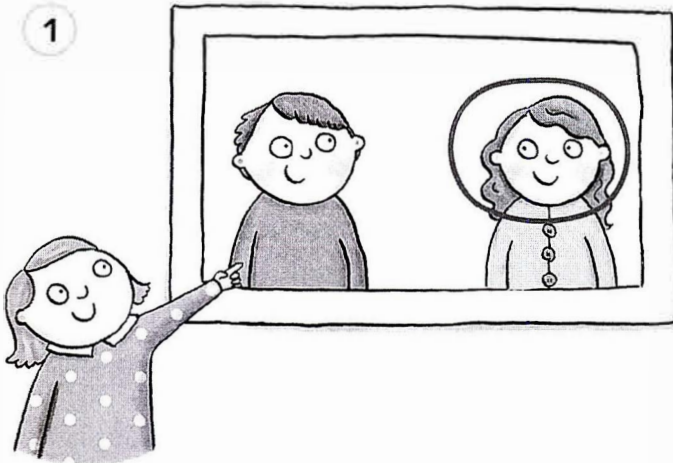

2

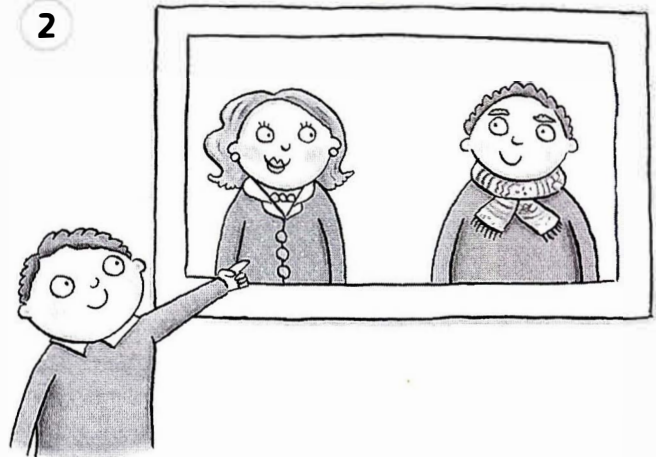

3

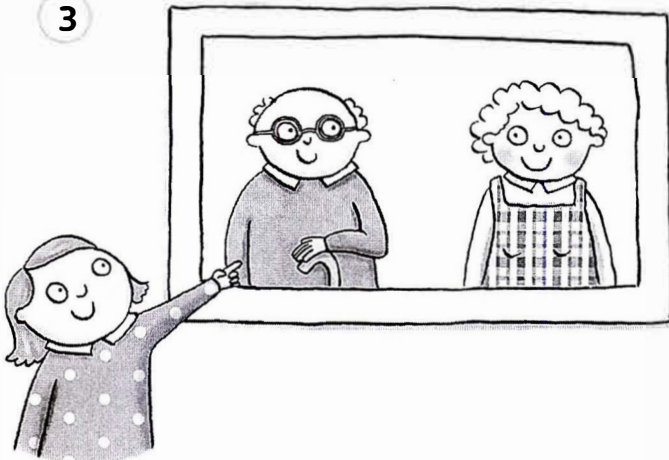

4

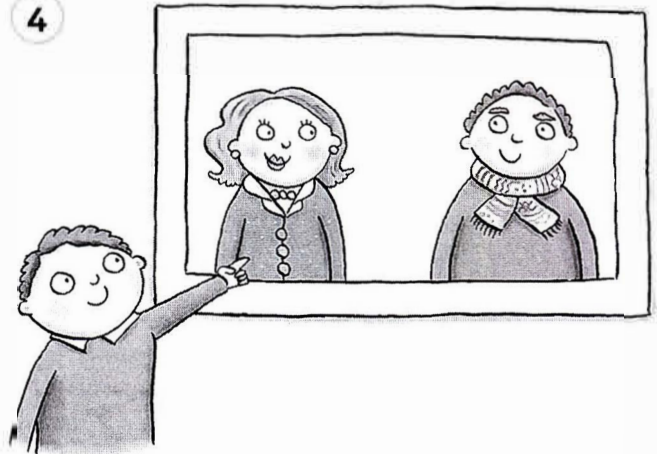

5

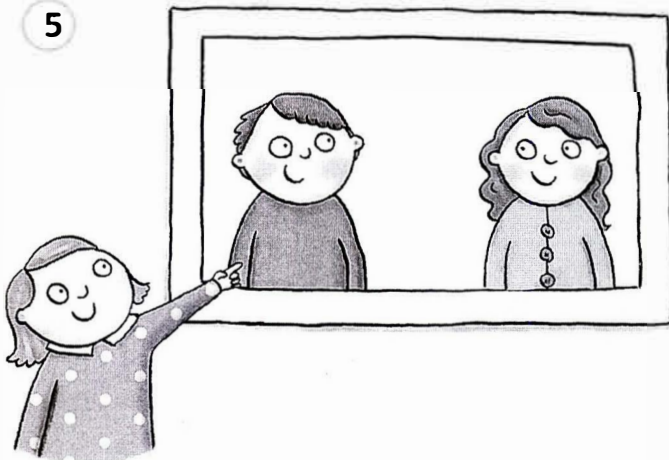

6

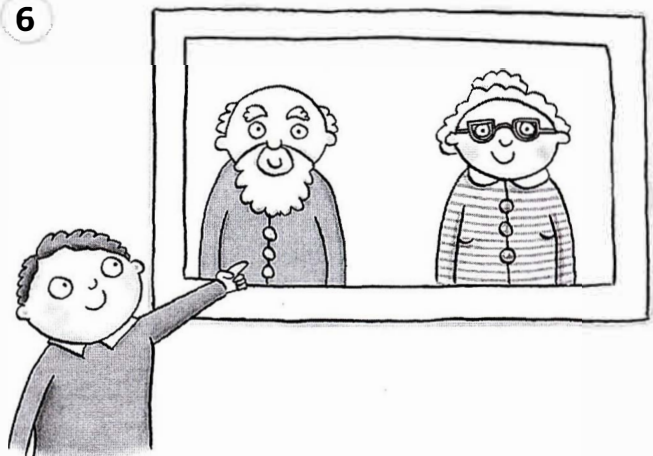

This is my (brother), (Tom).

1

Point and say the names and the words.

1



2



3



4



5



6



1

Draw lines. Colour and make sentences.

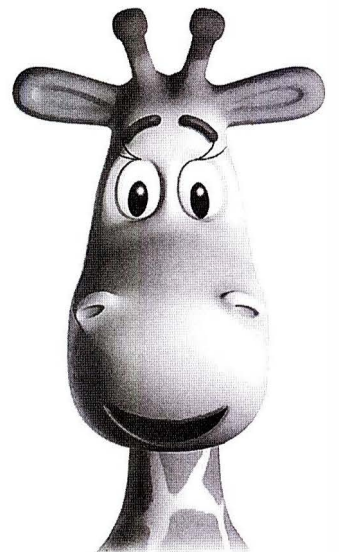
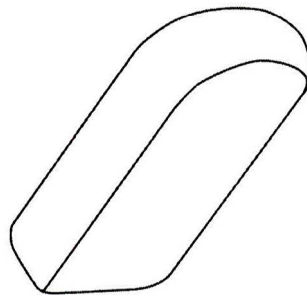
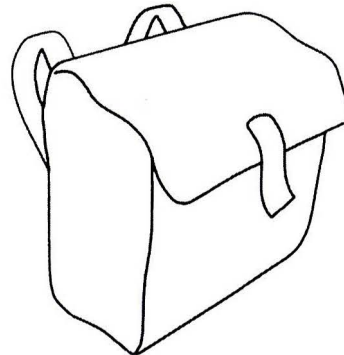
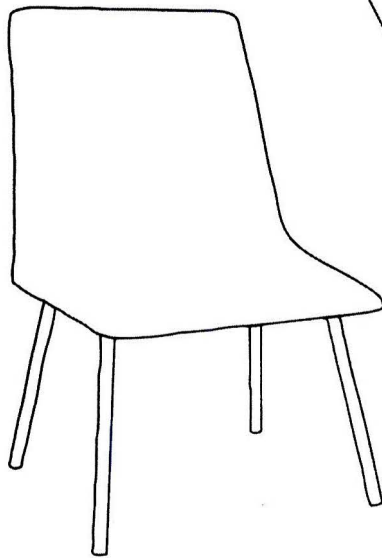
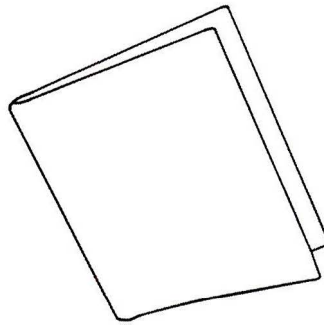
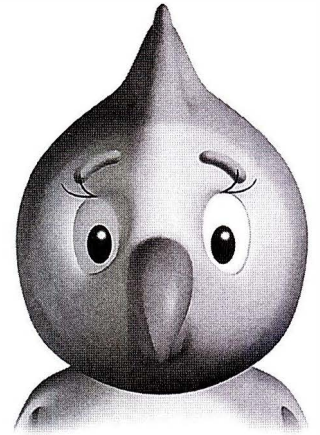

1

CD 1
30

Listen and trace.

1

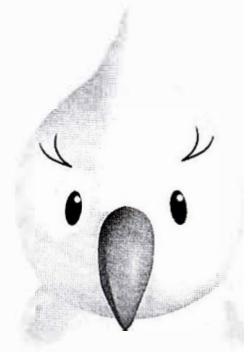
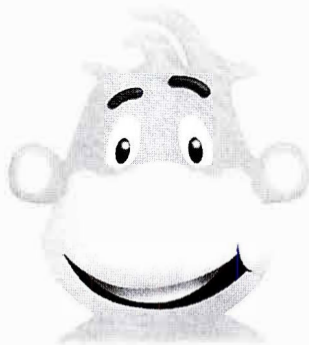

2

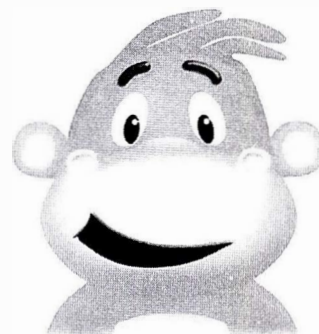
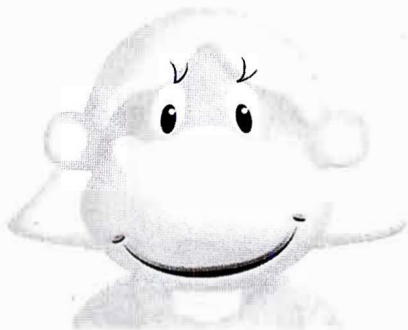

3

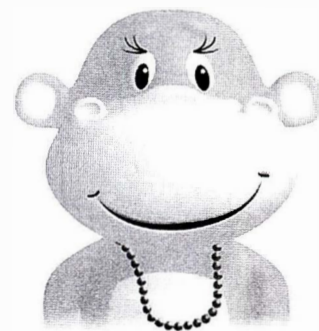
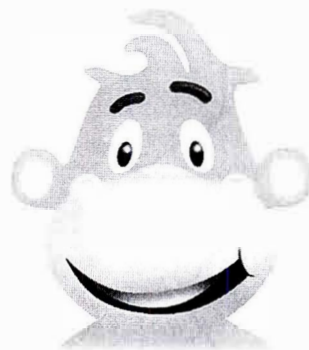

4

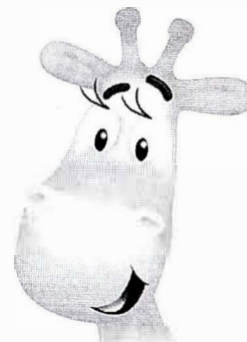
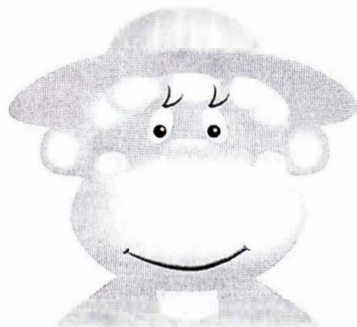

1 Think! Look and colour.

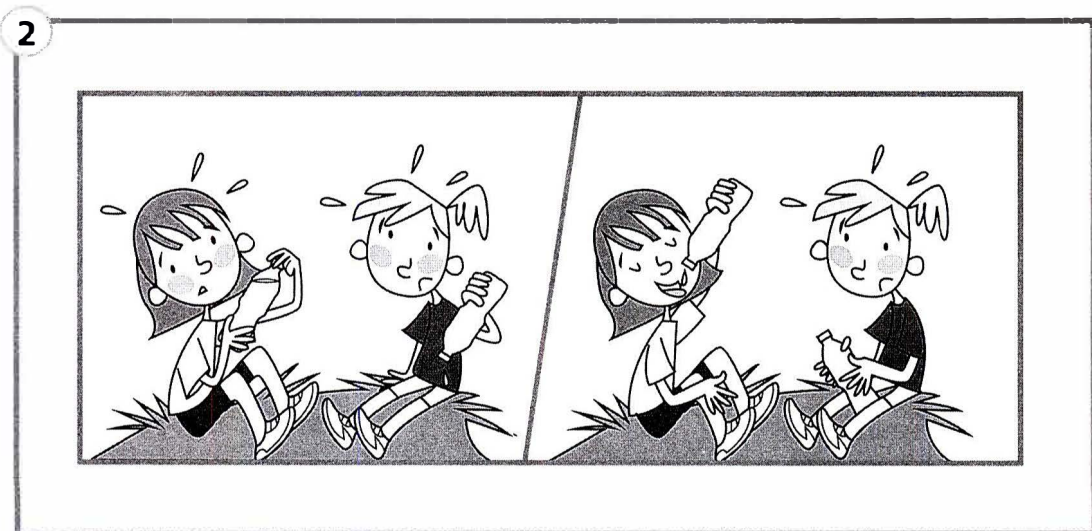
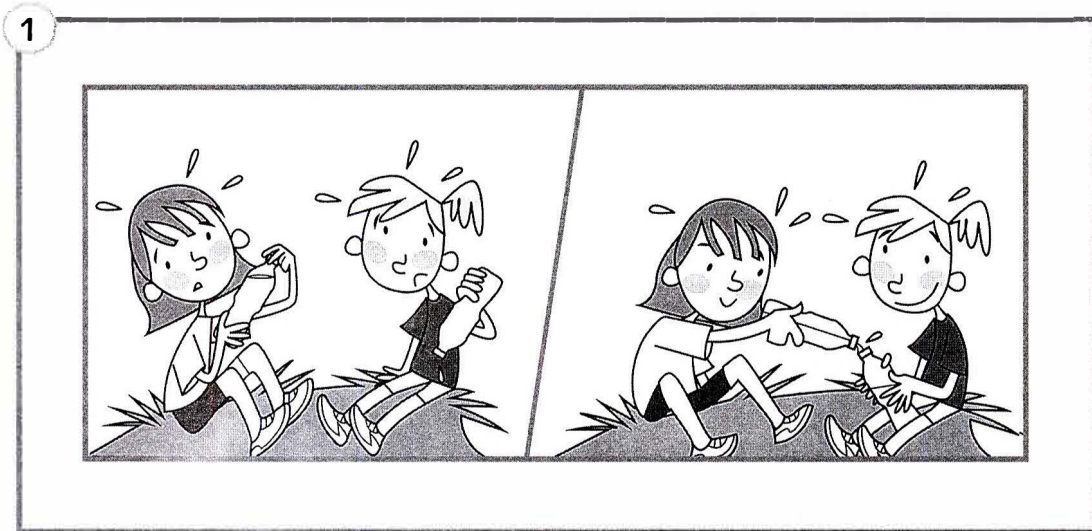
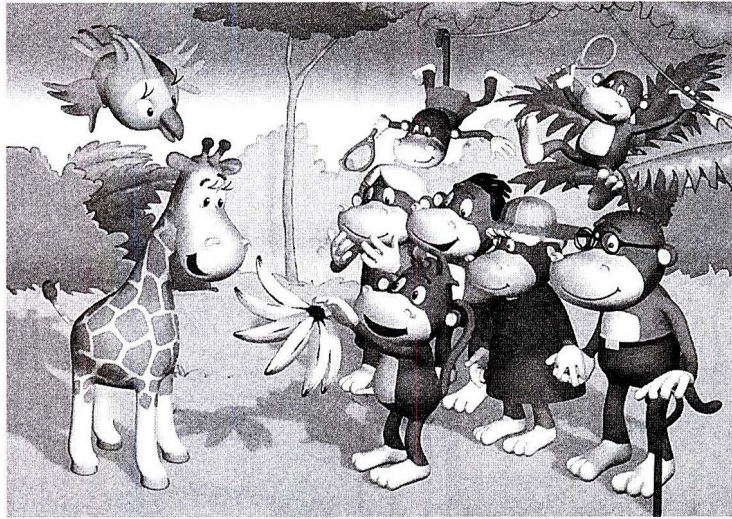

1 Look and draw.

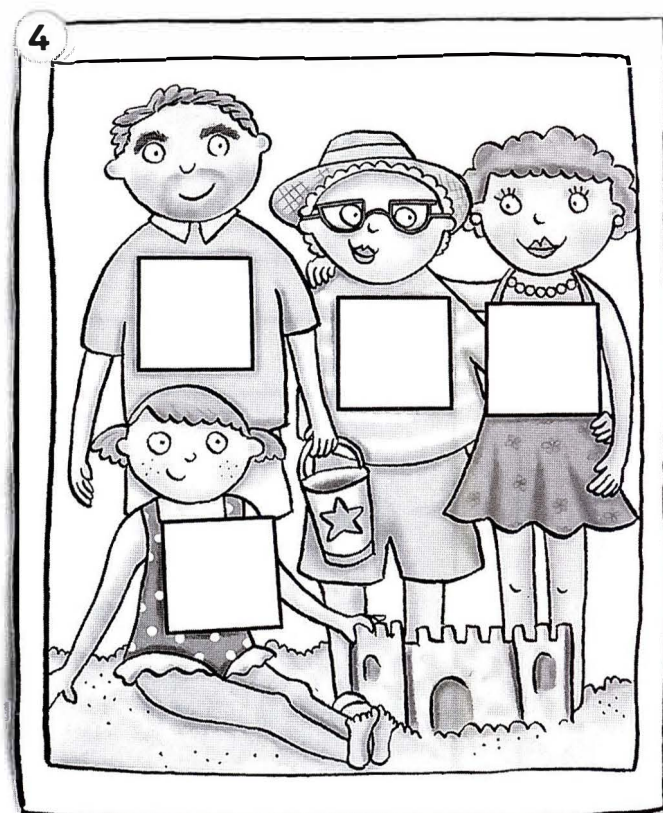
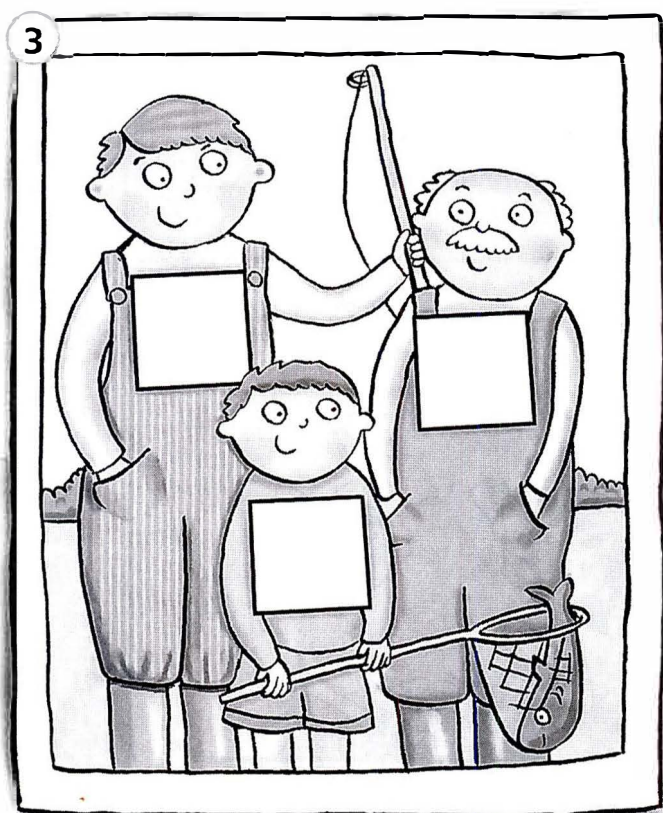
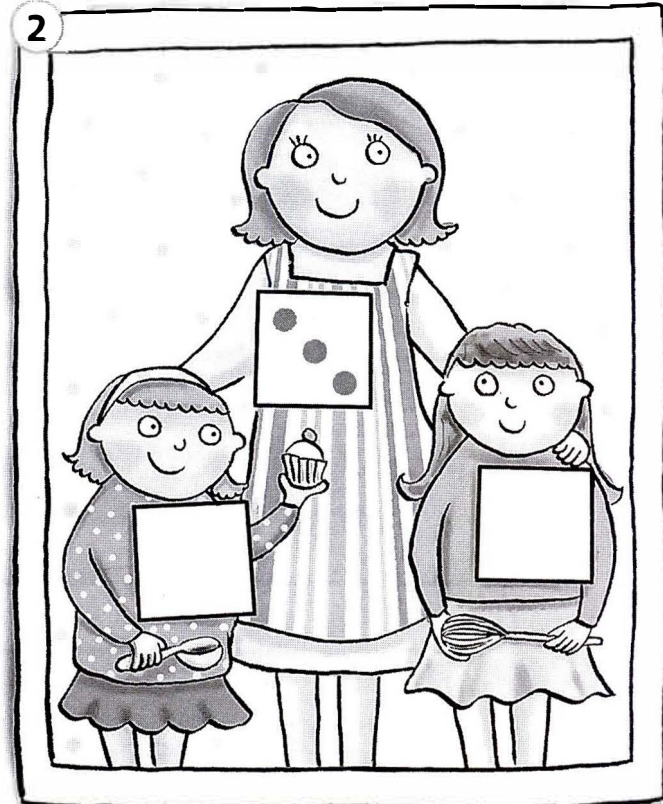
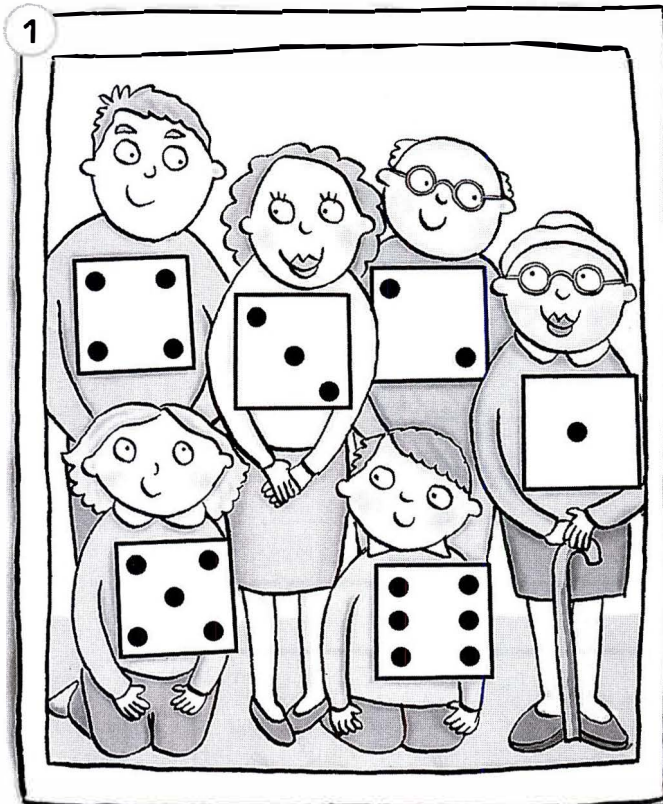
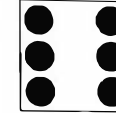
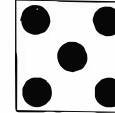
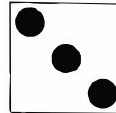
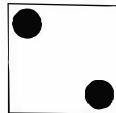
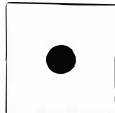

1 Think! Look and say the family words.

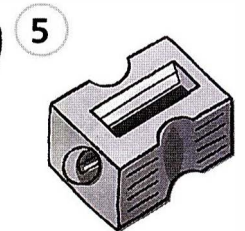
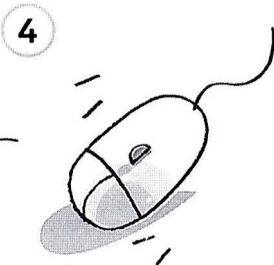
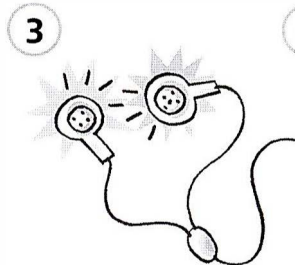
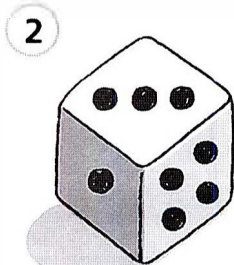
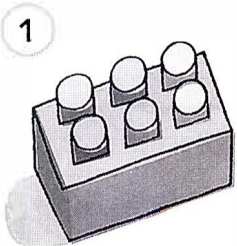
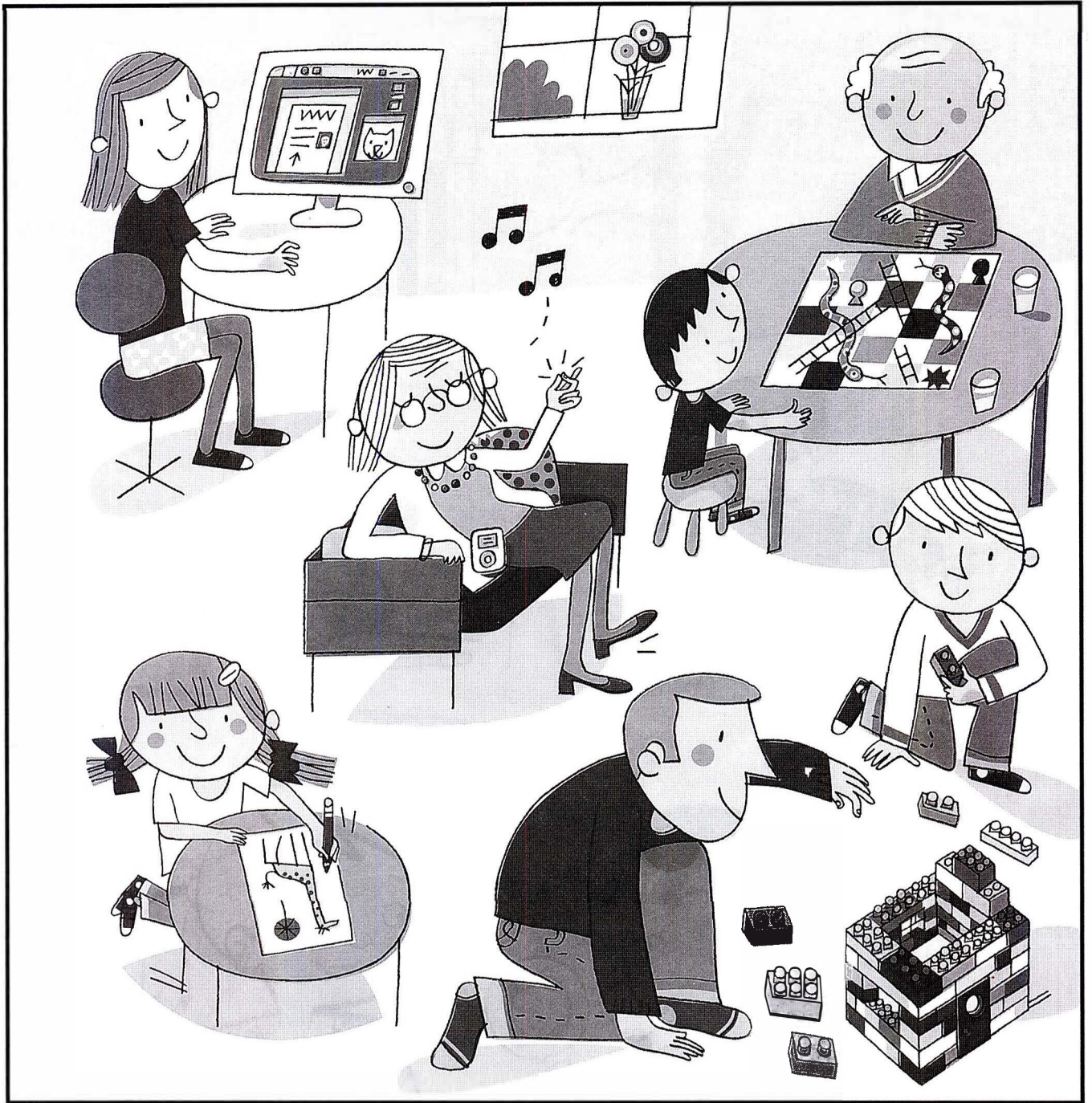

1 Make an ice lolly stick family.

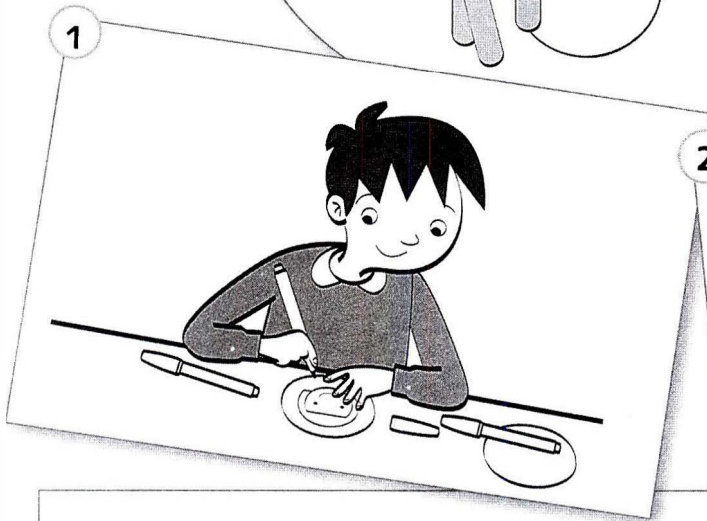
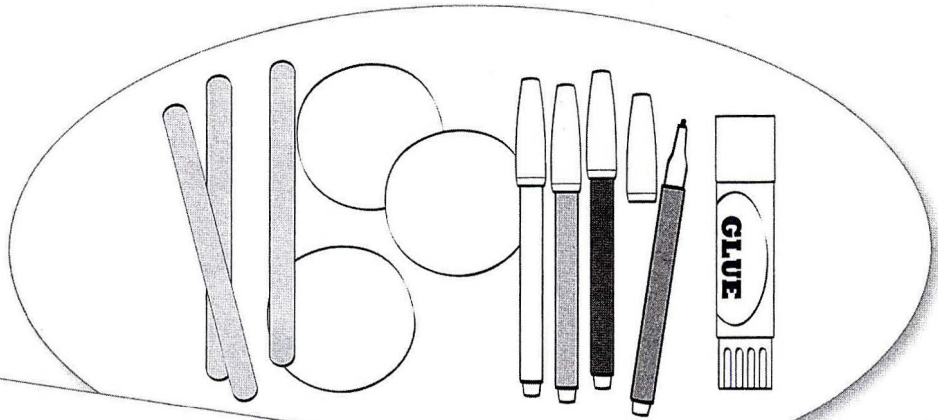

1

Say the words. Colour the circles.

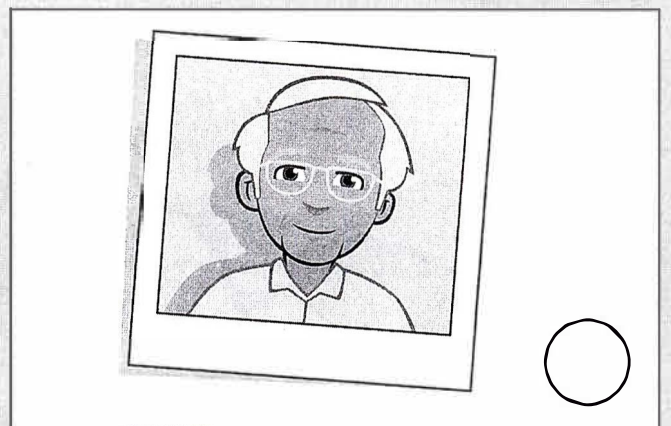
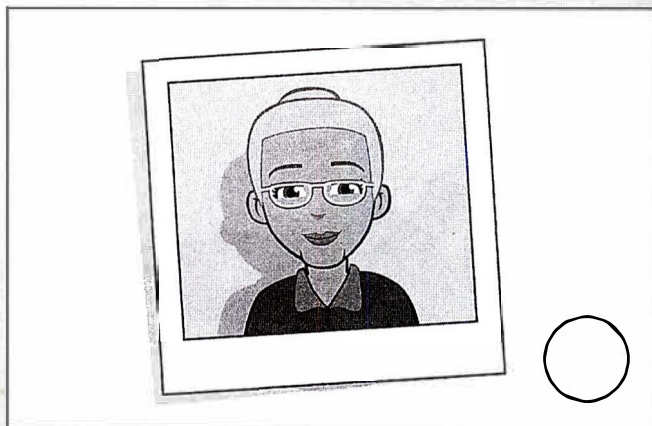
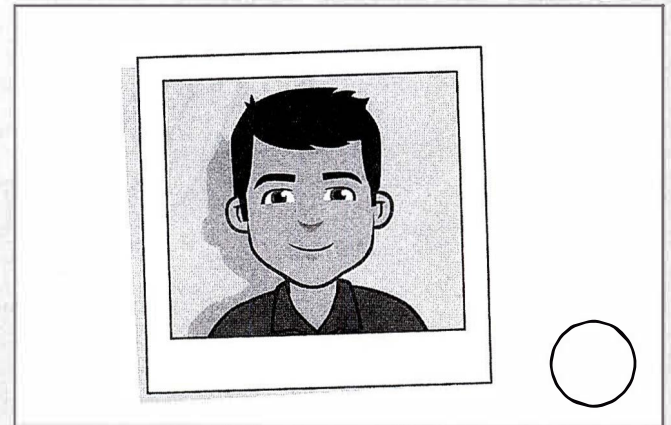
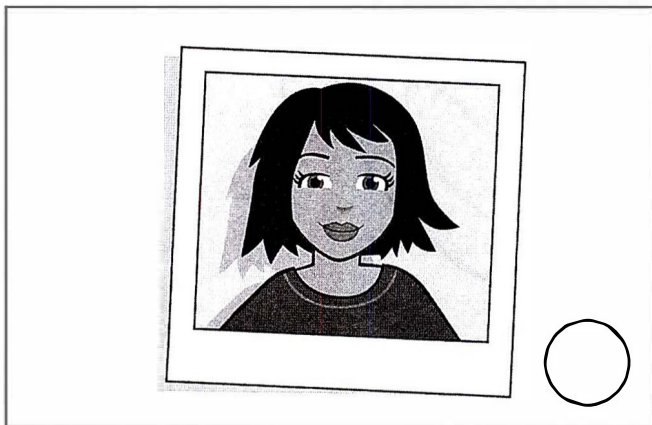
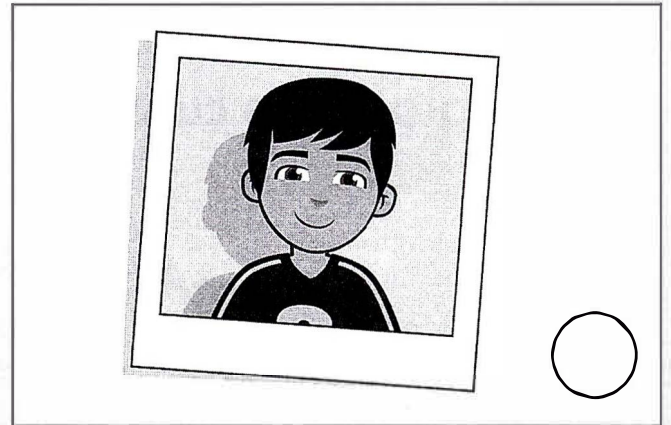
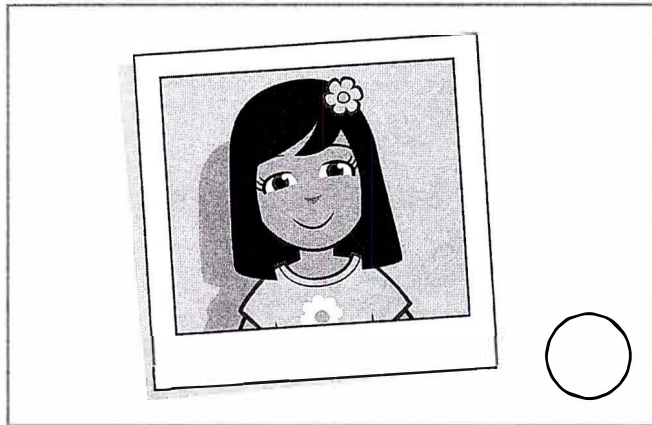

2

Draw faces. 😊 😐 😞

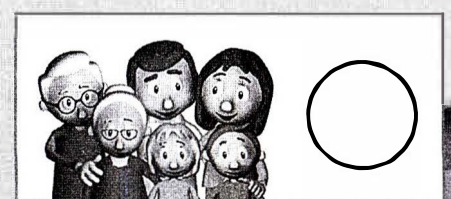
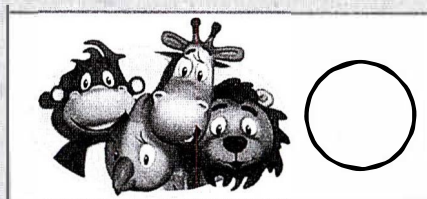
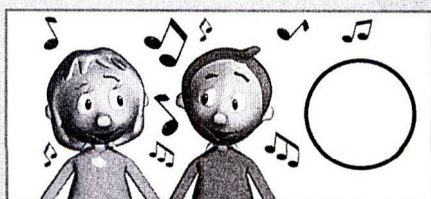

3

My face

1

Colour the clown.

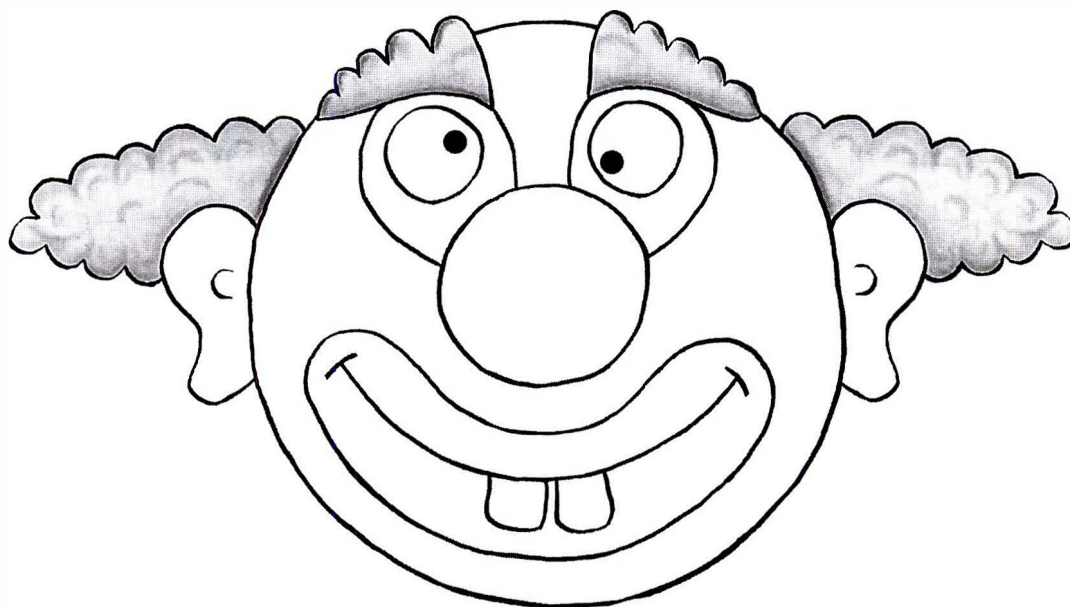



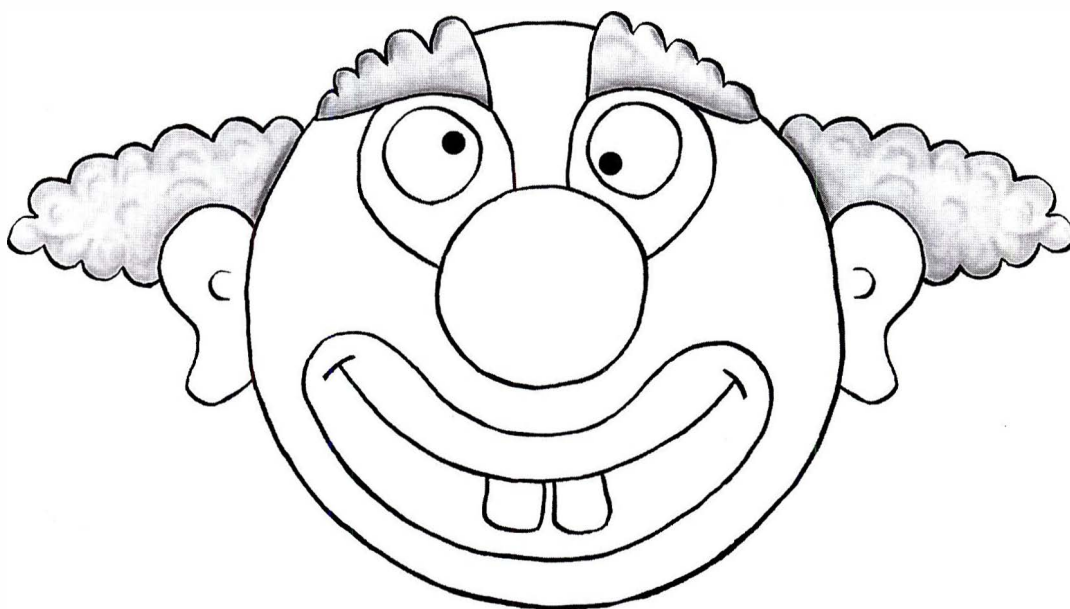

2

Describe your clown. Colour your friend's clown.



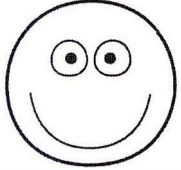
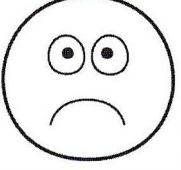

1 Think! Look, draw and say the words.

1

					
---	---	---	--	---	---

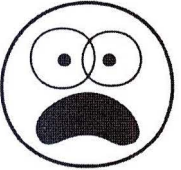
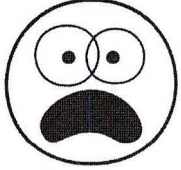

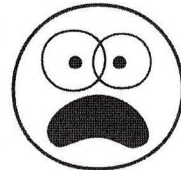
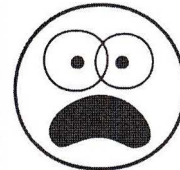
2

					
---	---	---	--	---	--

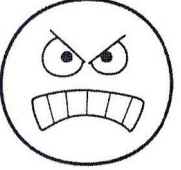
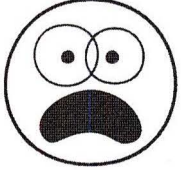
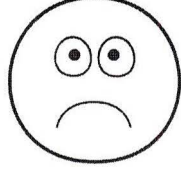
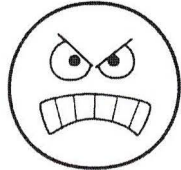
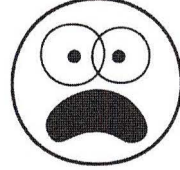
3

					
---	---	---	--	---	--

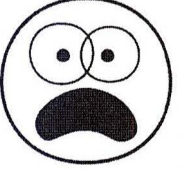
4

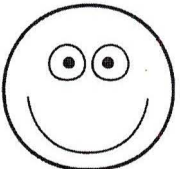
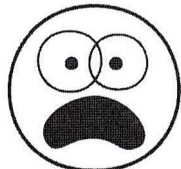
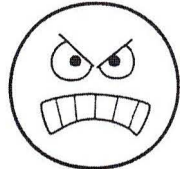
					
---	---	---	--	---	--

1

How are you feeling today? Complete the face.

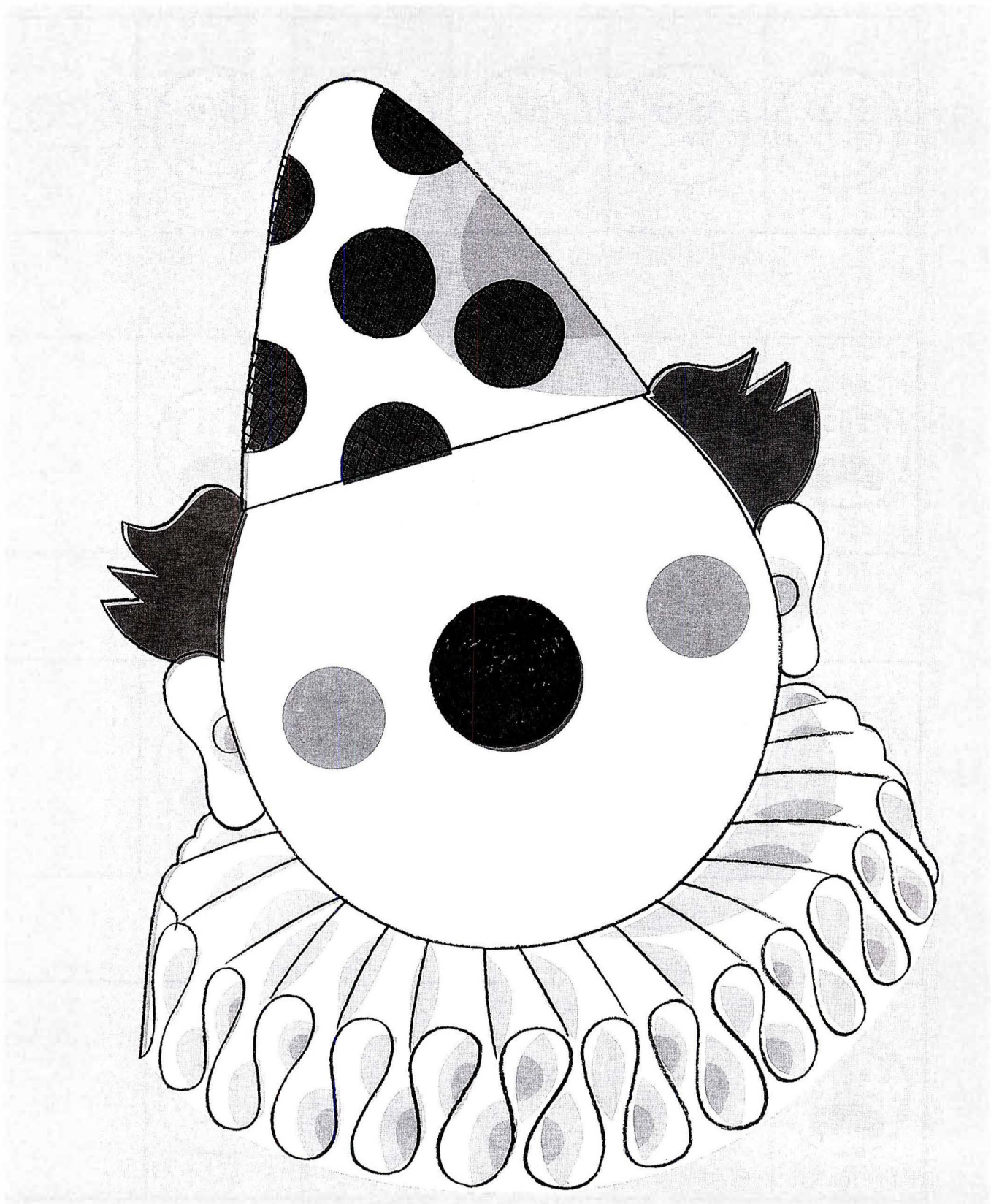

1 CD1
40 Listen and circle.

1

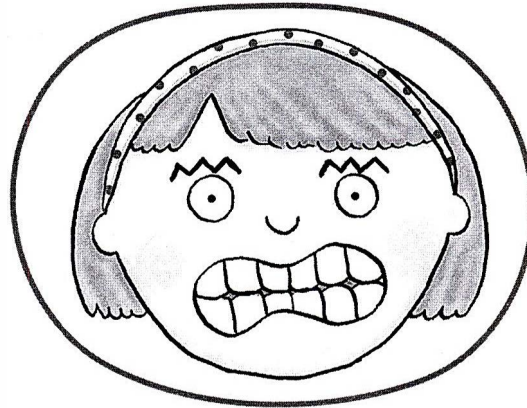
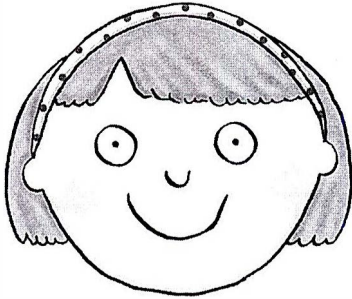

2

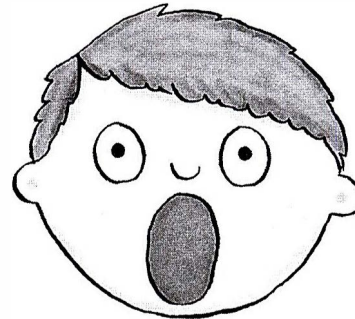
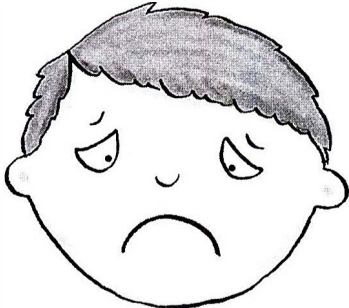

3

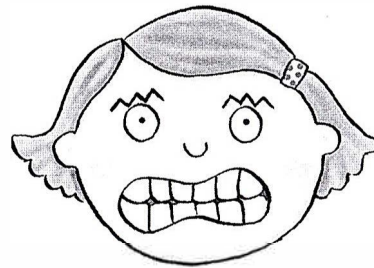
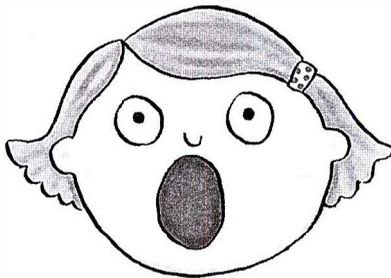

4

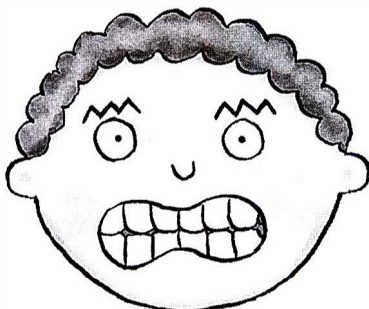

Are you (angry)? Yes, I am. / No, I'm not.

1  Listen and trace.

1

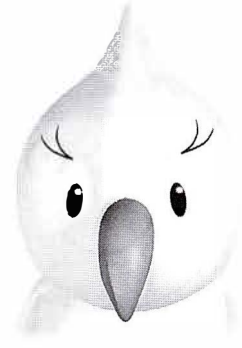
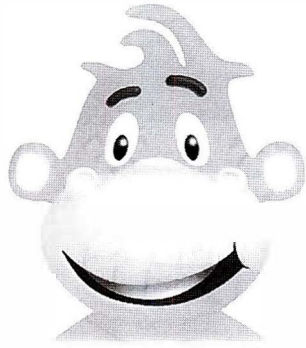

2

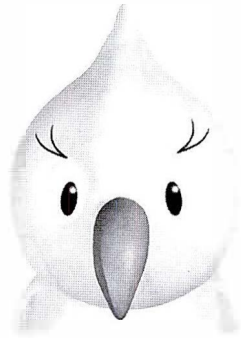

3

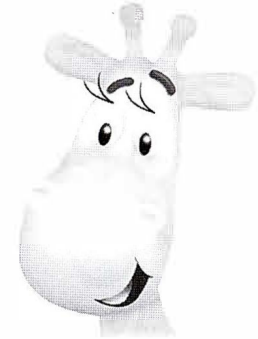
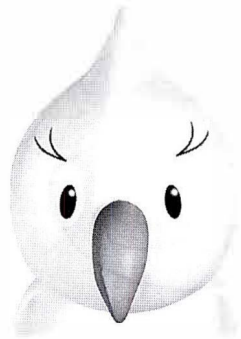

4

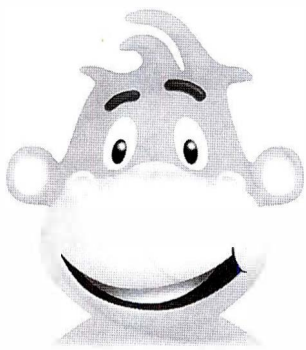

1 Think! Look and colour.

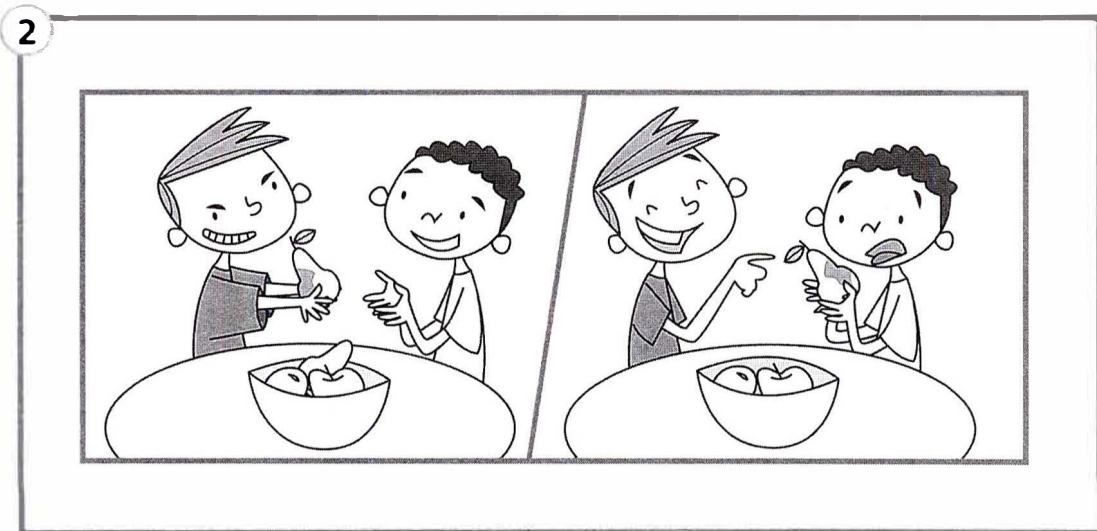
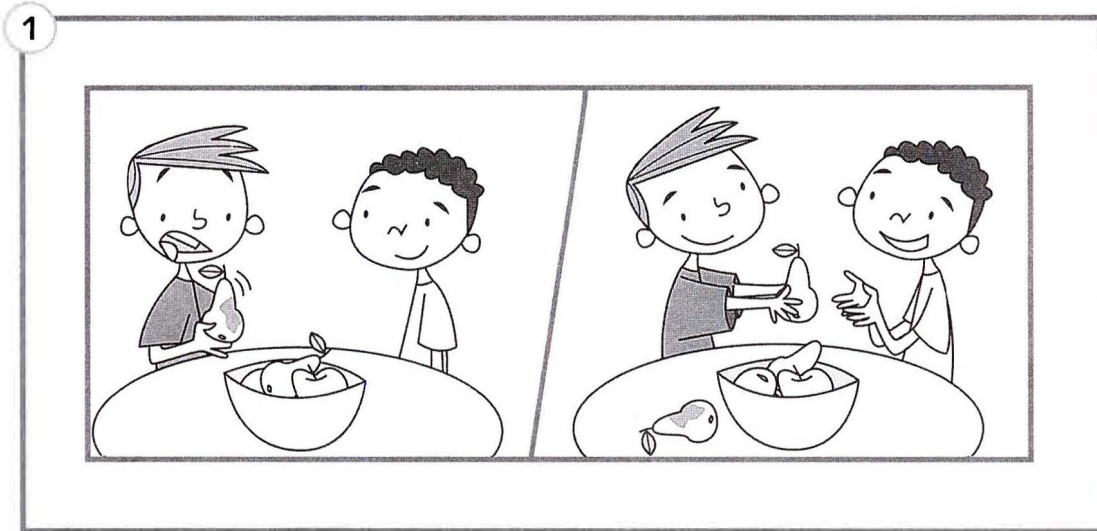
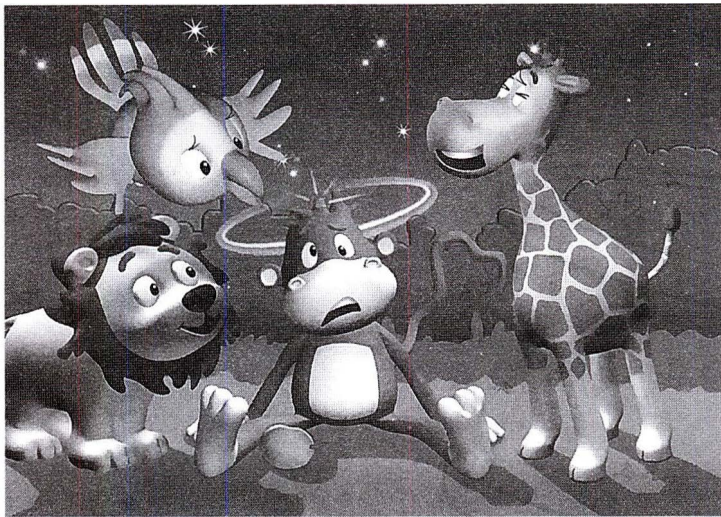

1 Think! Join the dots and answer.

1

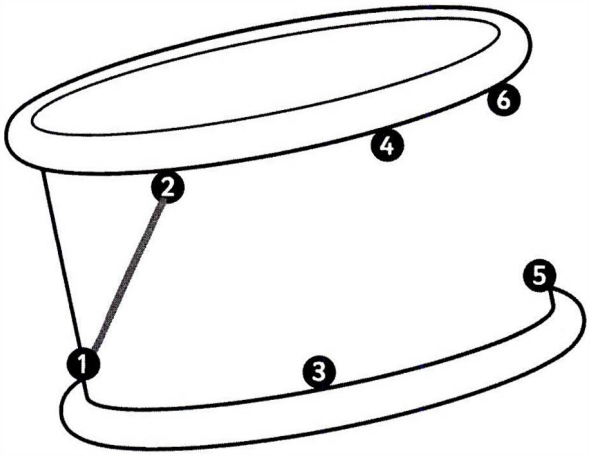

2

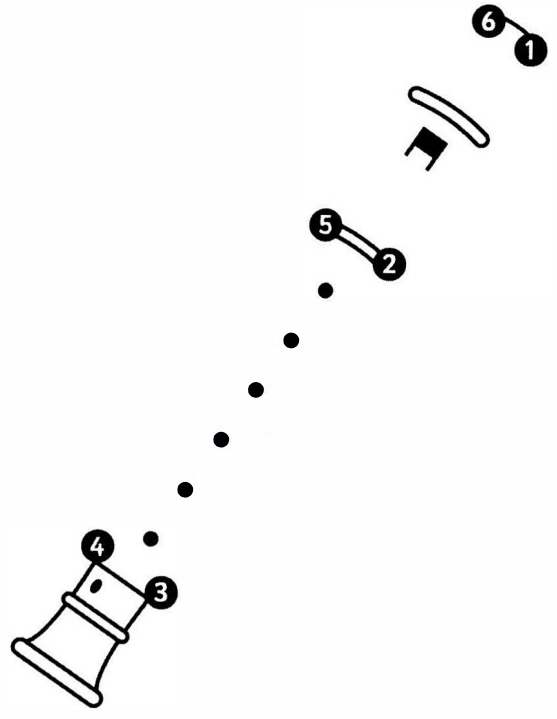

3

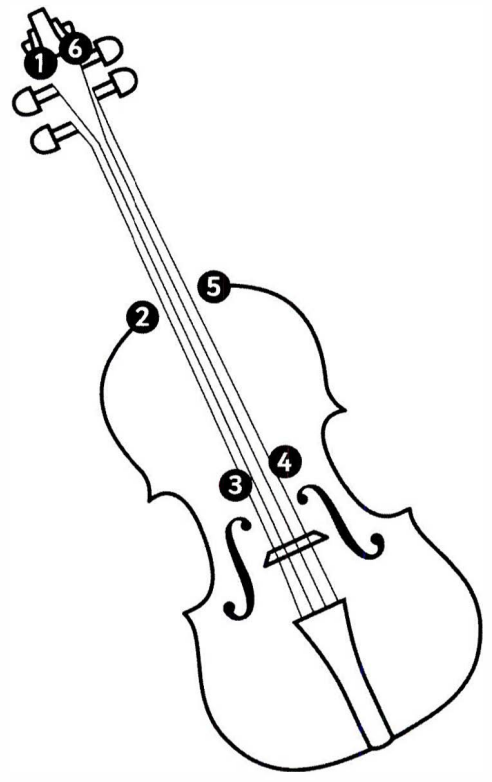

4

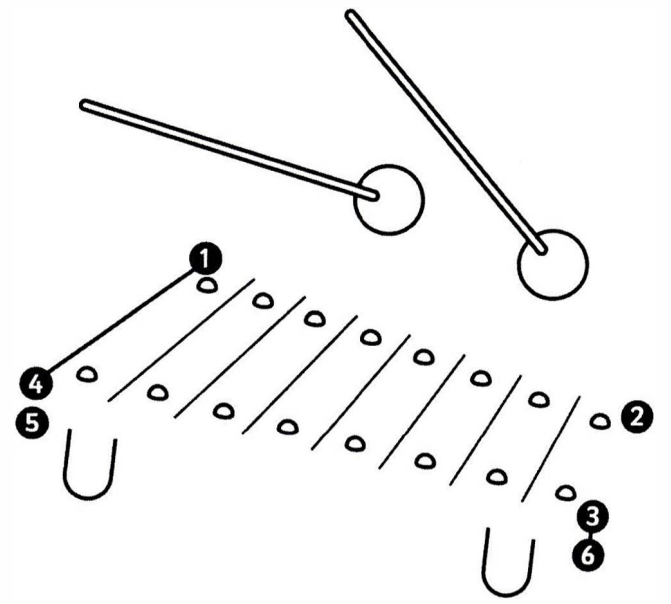

1 Think! Look and draw.

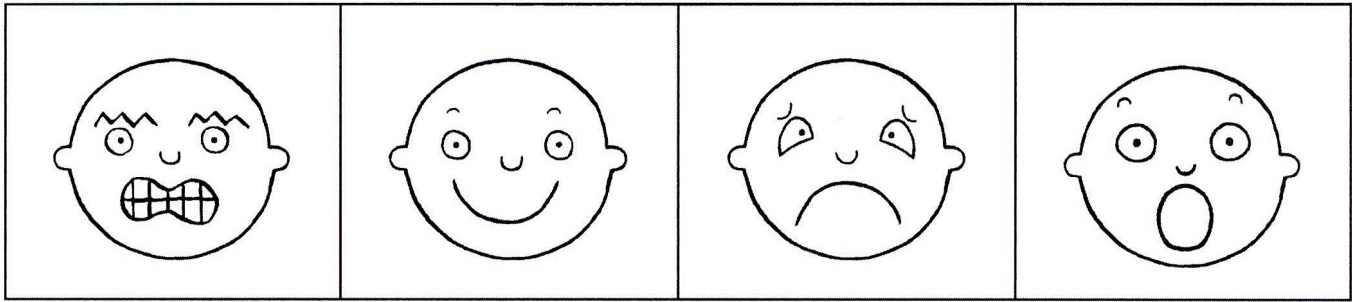

1 Make a xylophone.

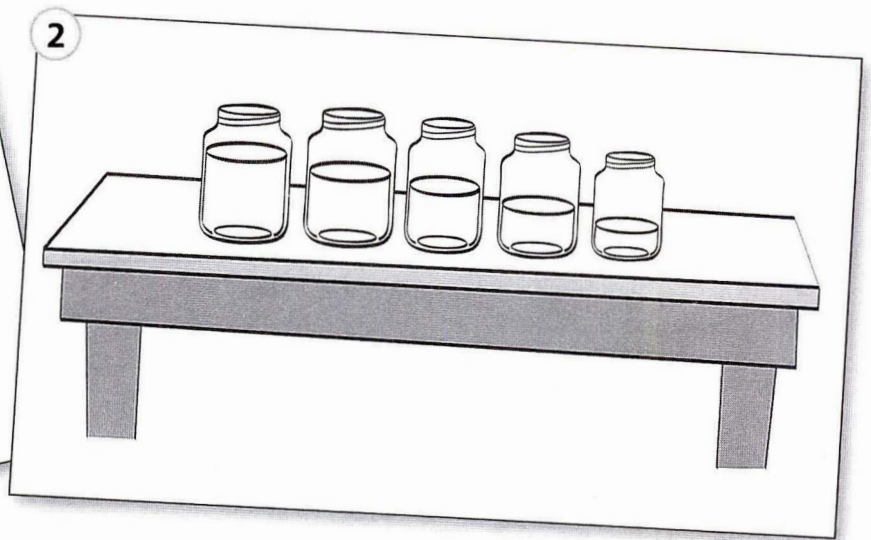

1 Say the words. Colour the circles.

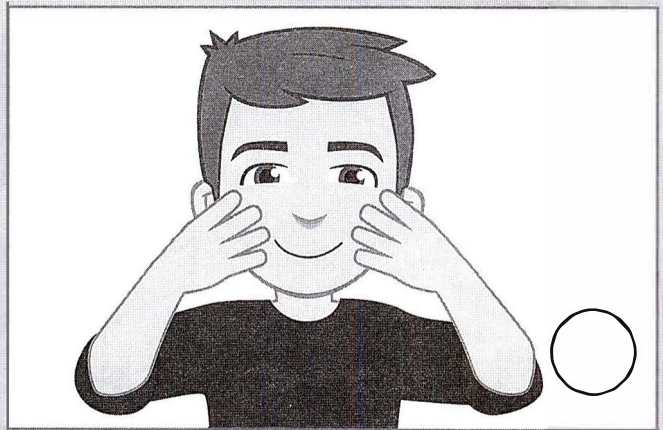
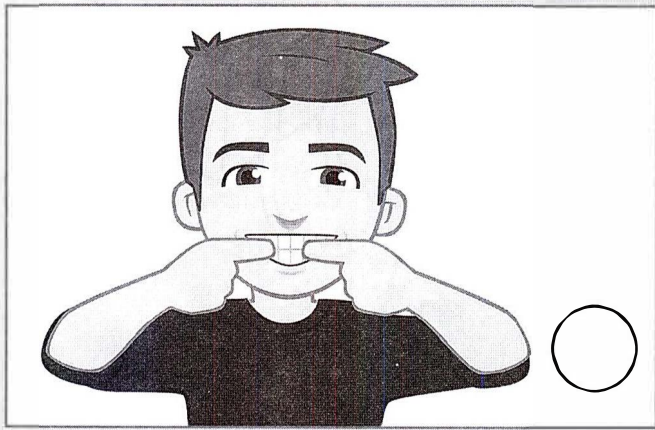
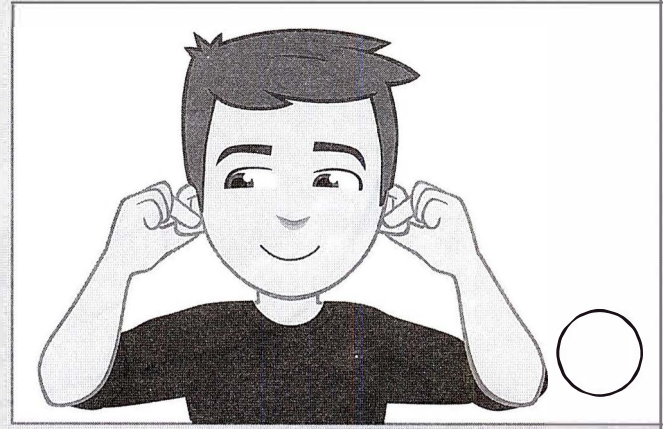
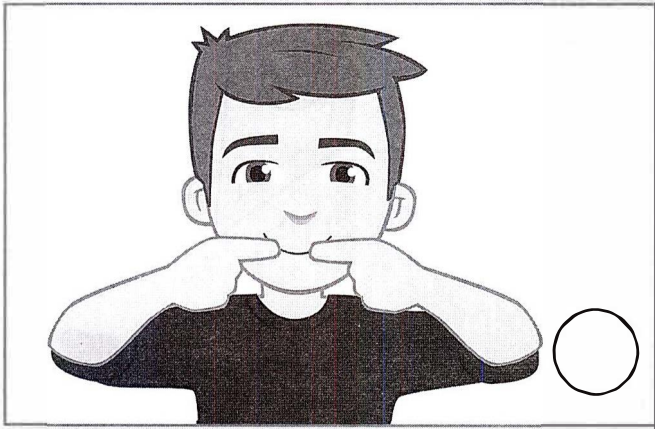
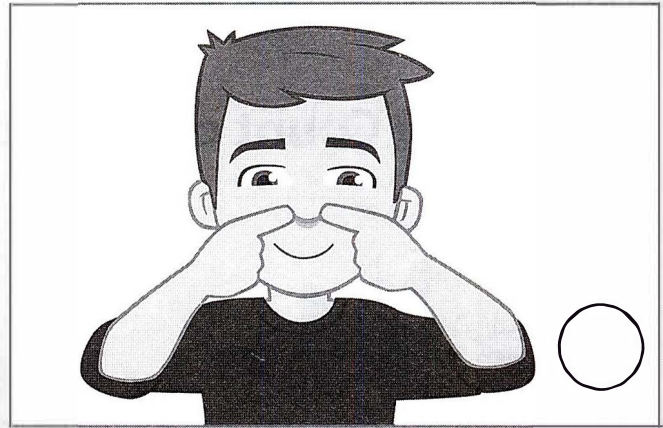
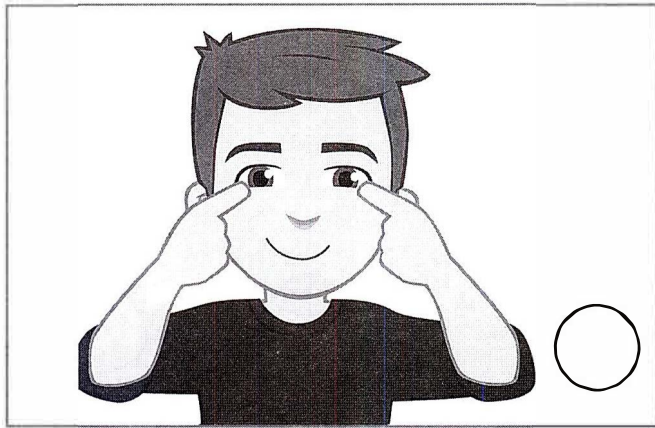

2 Draw faces. 😊 😐 😞

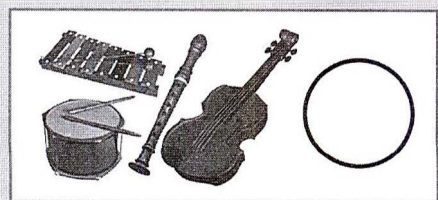
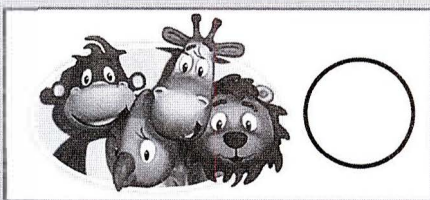
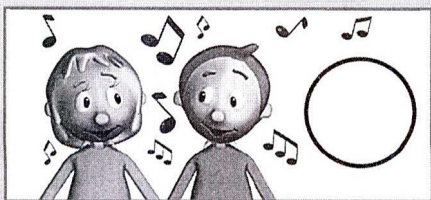

4

Toys

1

Think! Count and match.

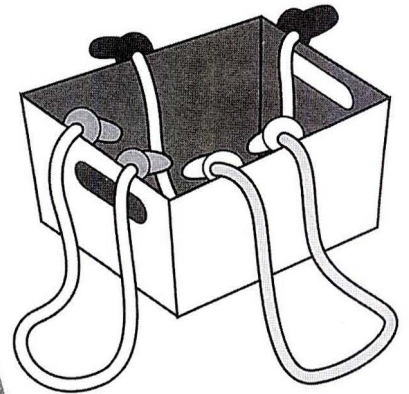
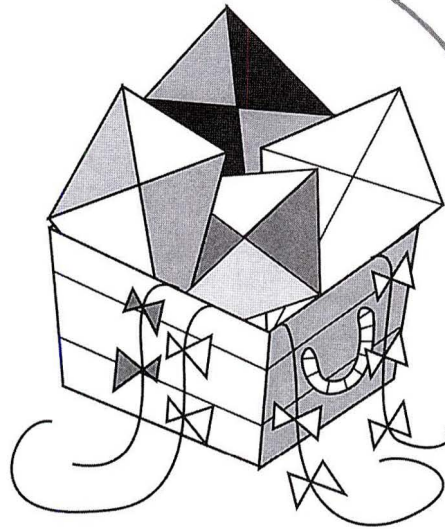
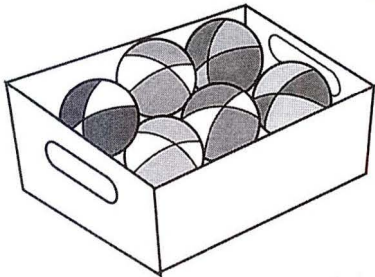
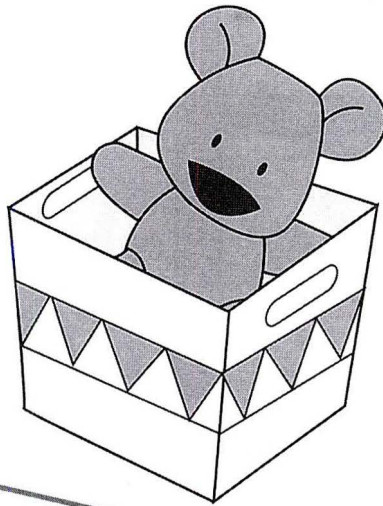
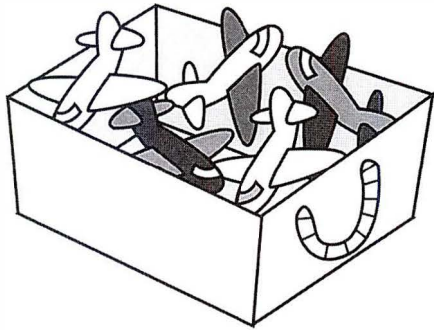

1

2

3

4

5

6

1 Draw four toys.

www.irLanguage.com

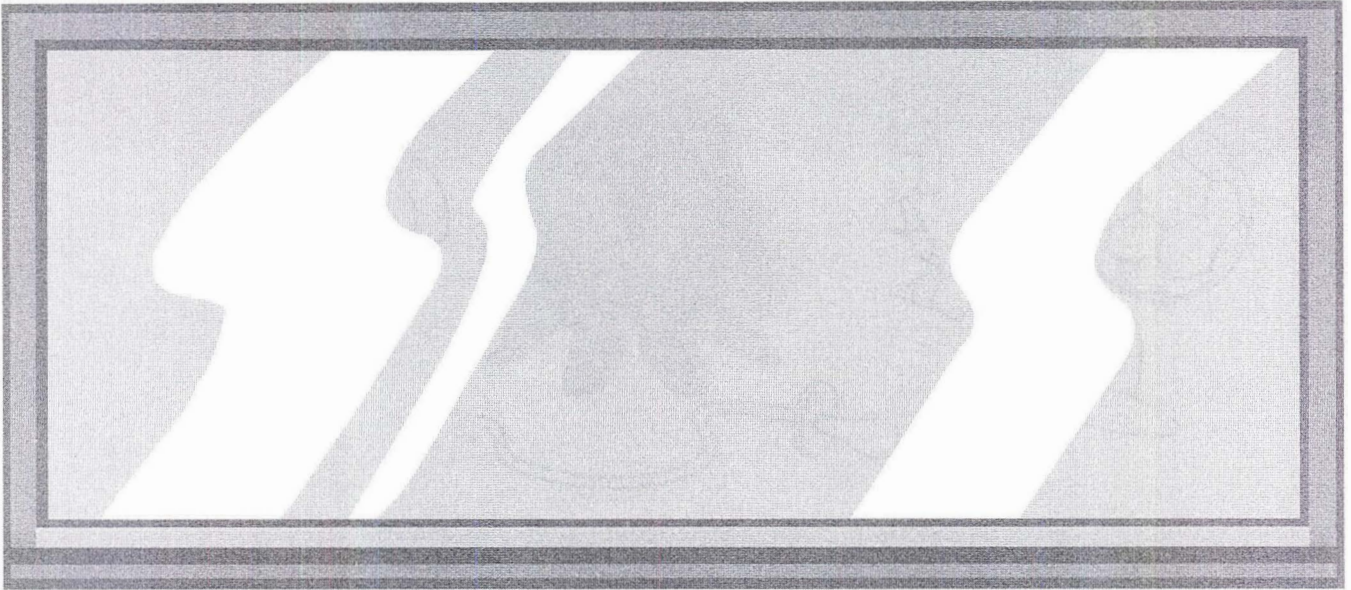
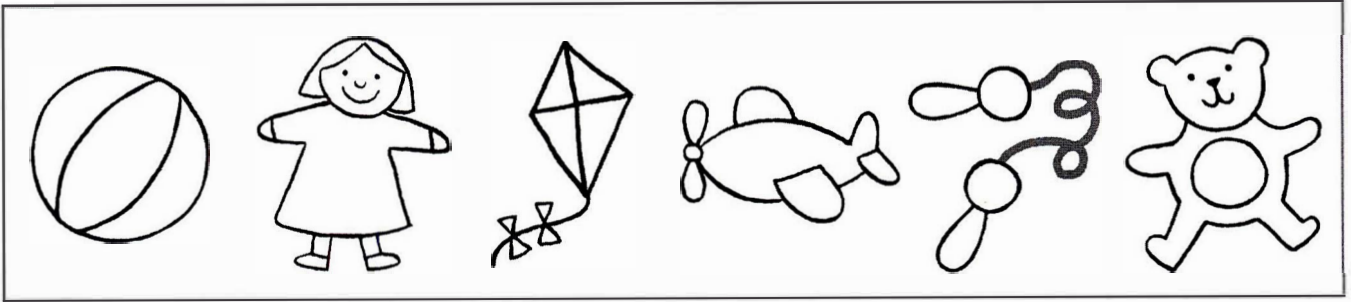

2 Describe your picture. Draw your friend's picture.

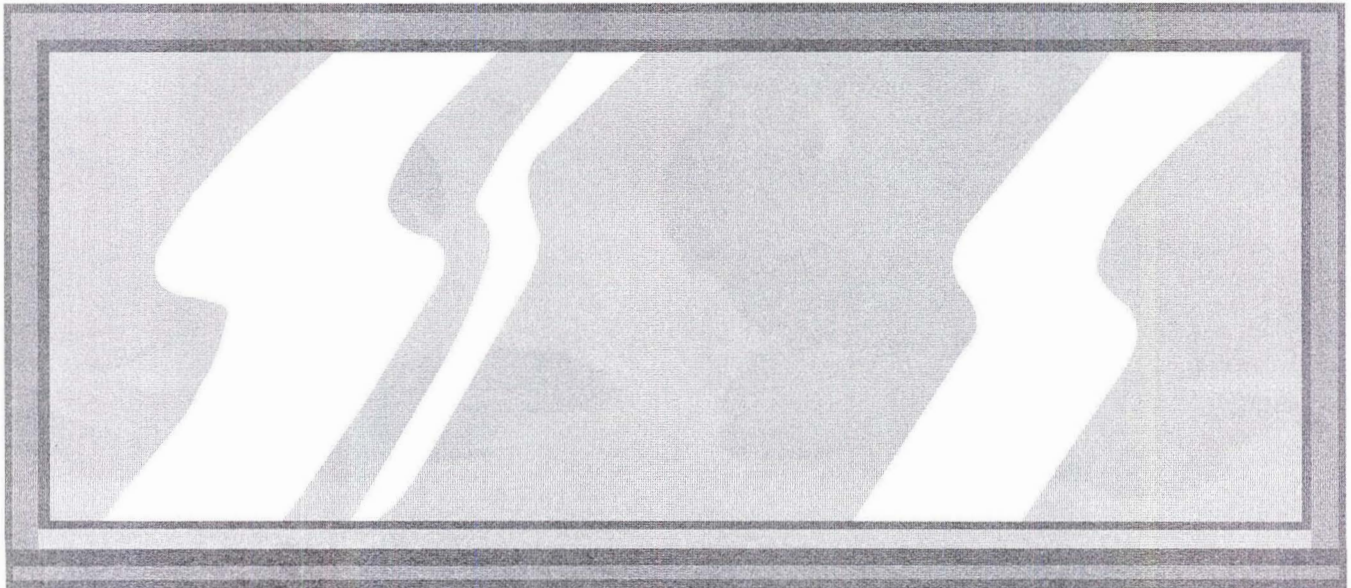

1

Complete the toys. Draw the missing toy.

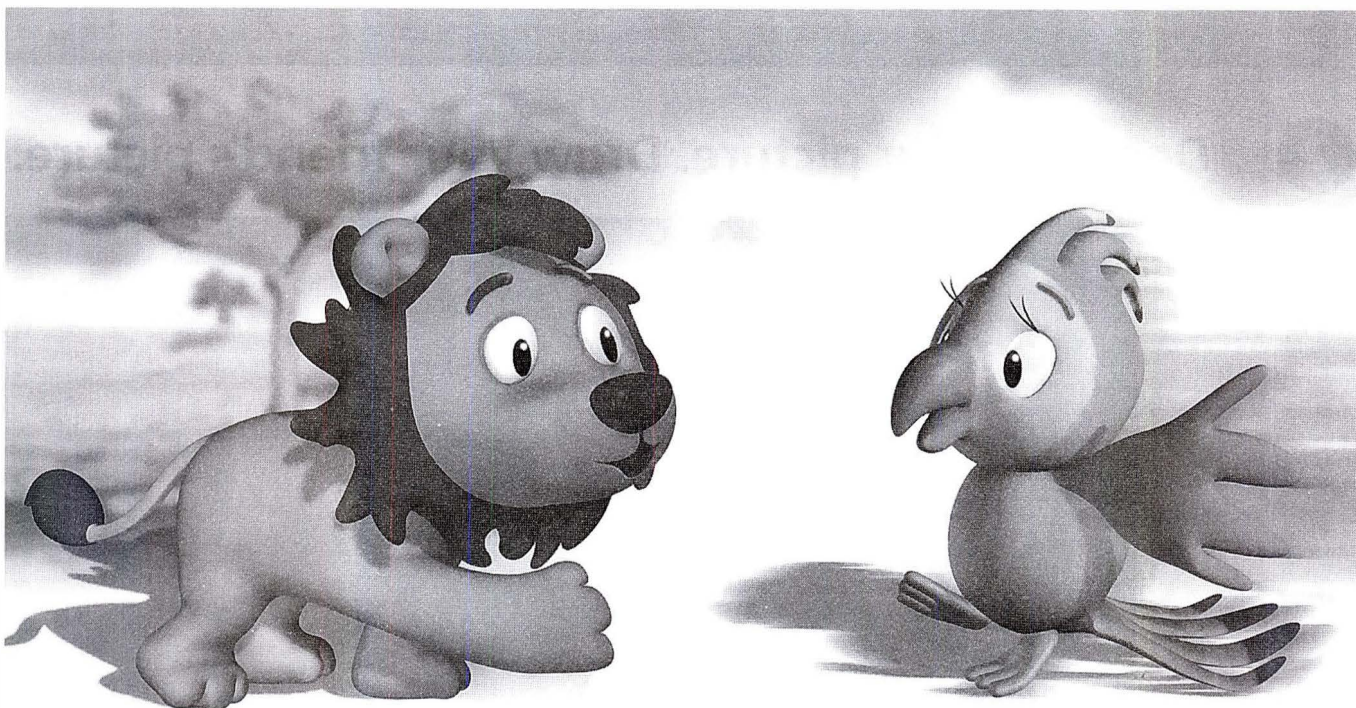
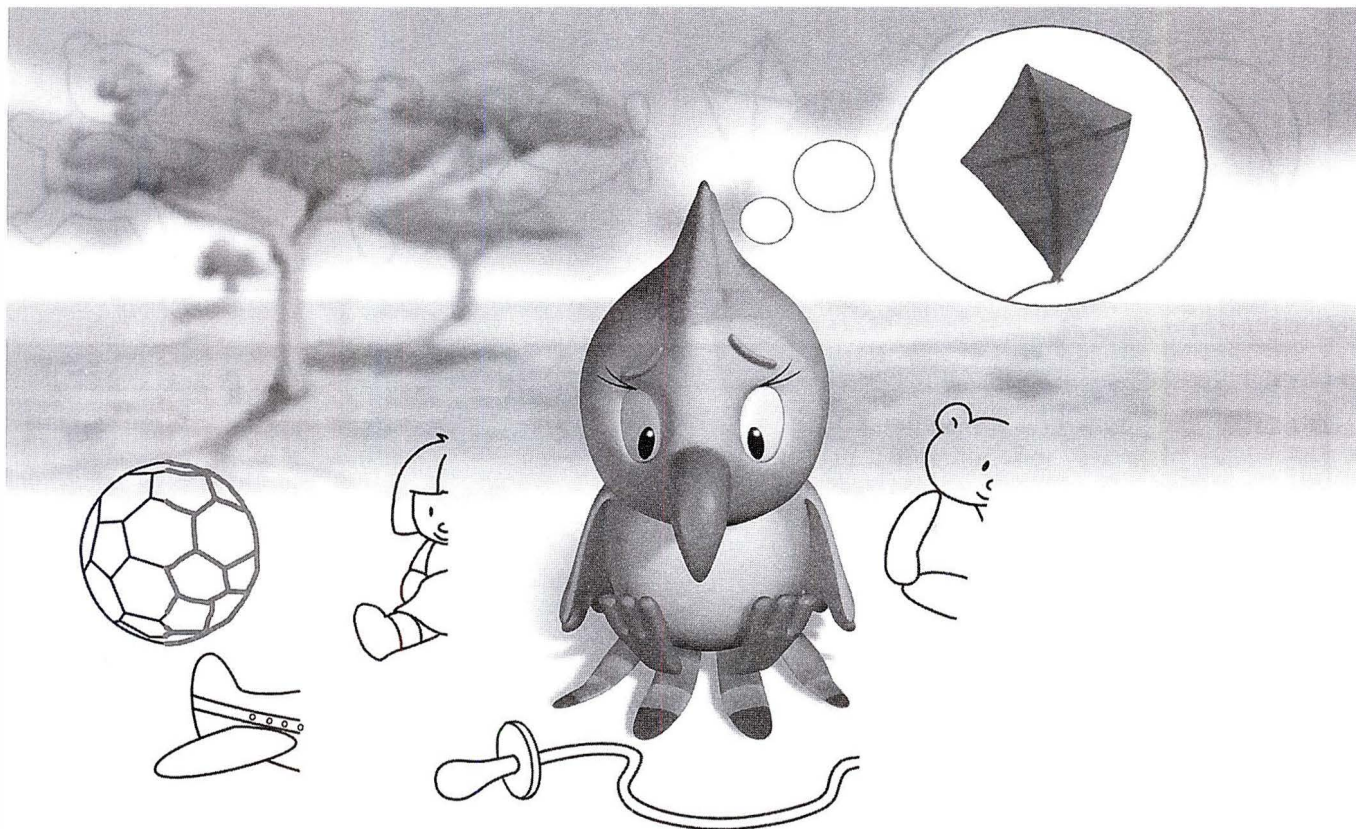

1  Listen and colour.

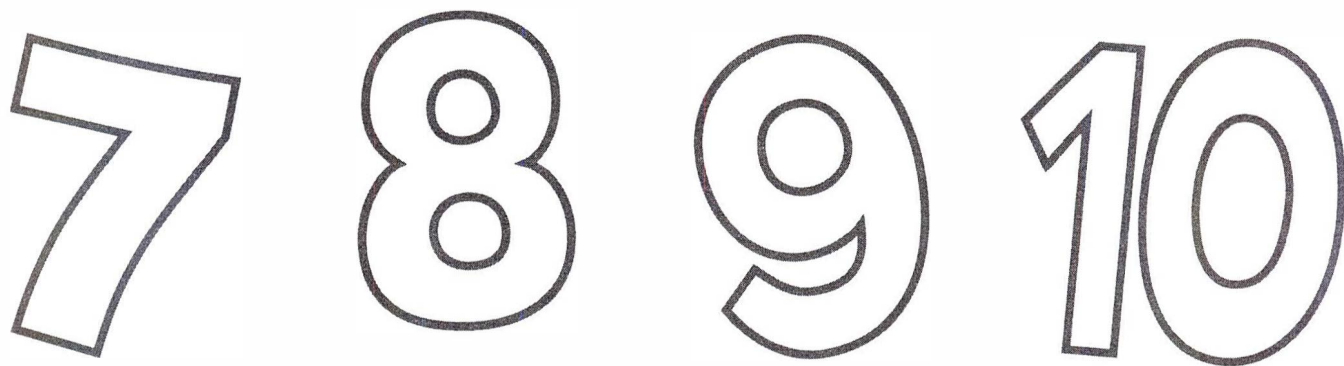

2  Think! Count and draw.

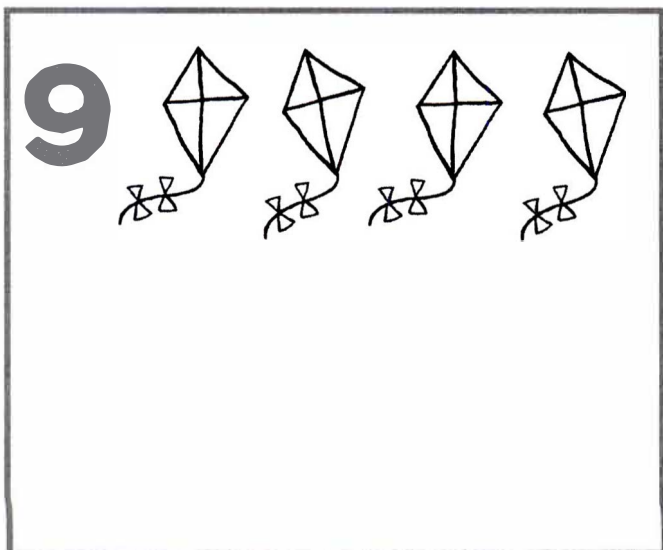
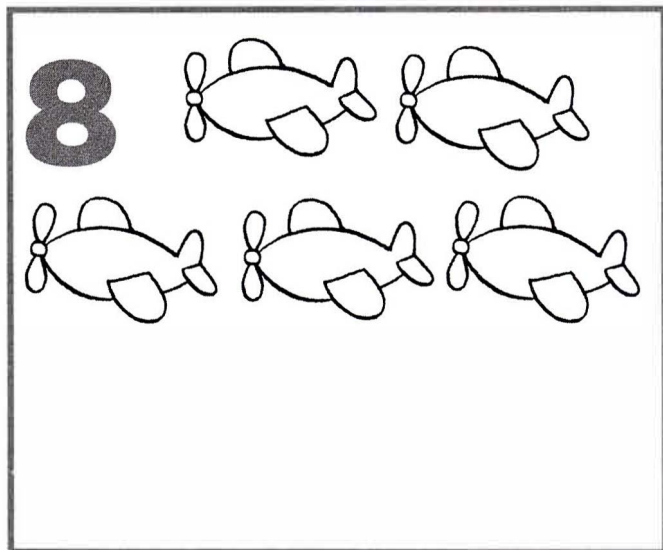
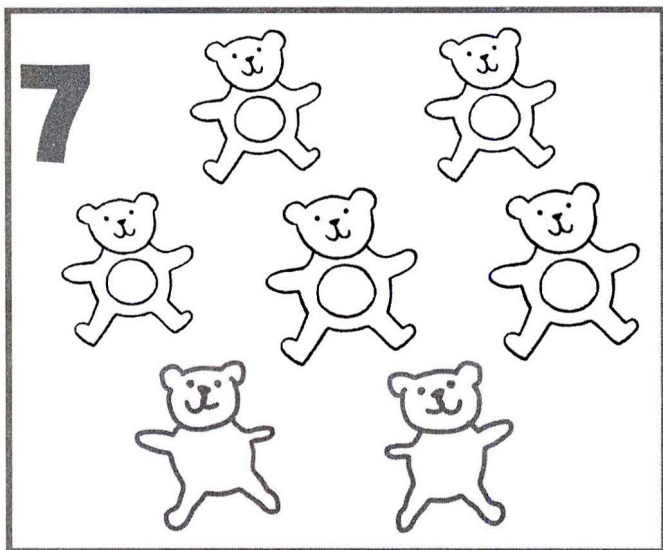

1 CD 1
5

Listen and trace.

1

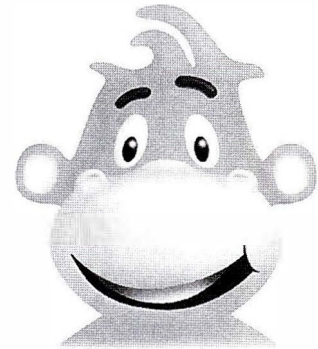
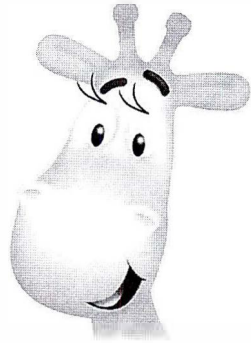

2

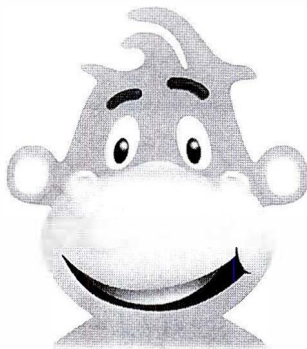

3

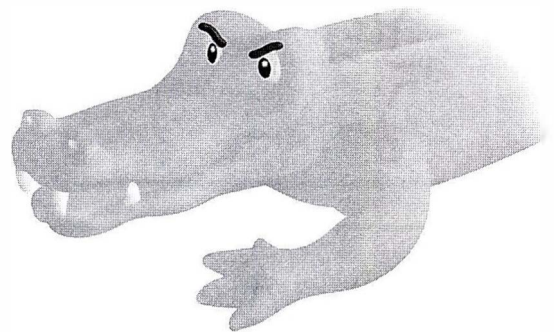
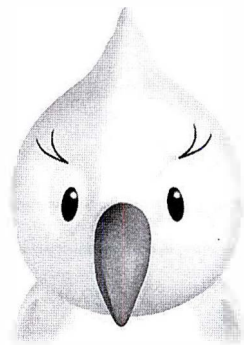

4

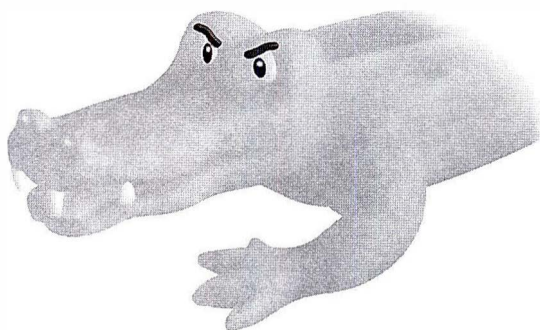

1

Think! Look and colour.



1

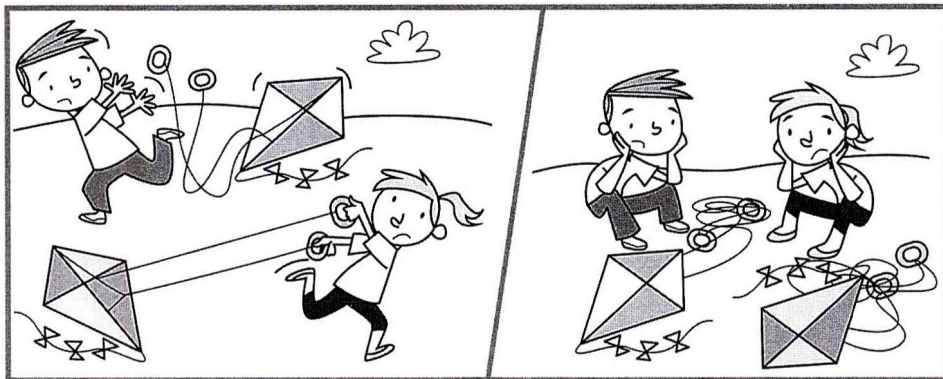

2

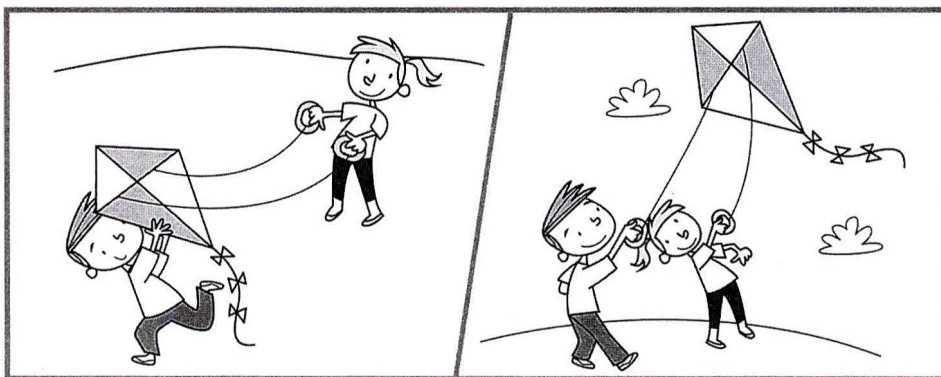

1

Look and draw two ropes and three balls.



1

Think!

Look and circle red

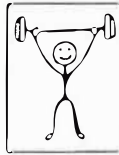

and blue

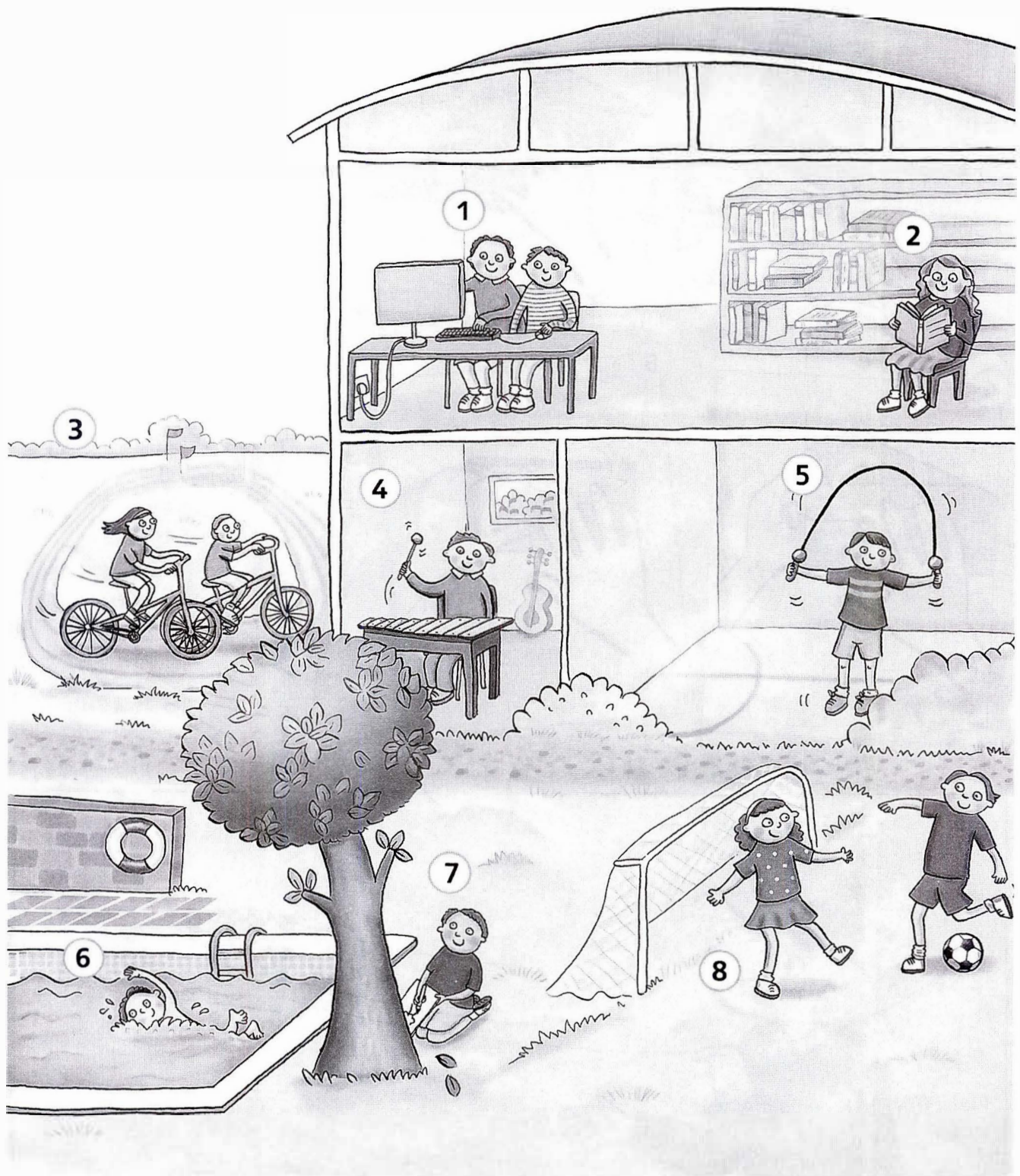
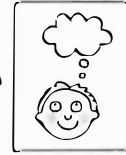

1 Make a paper plane.

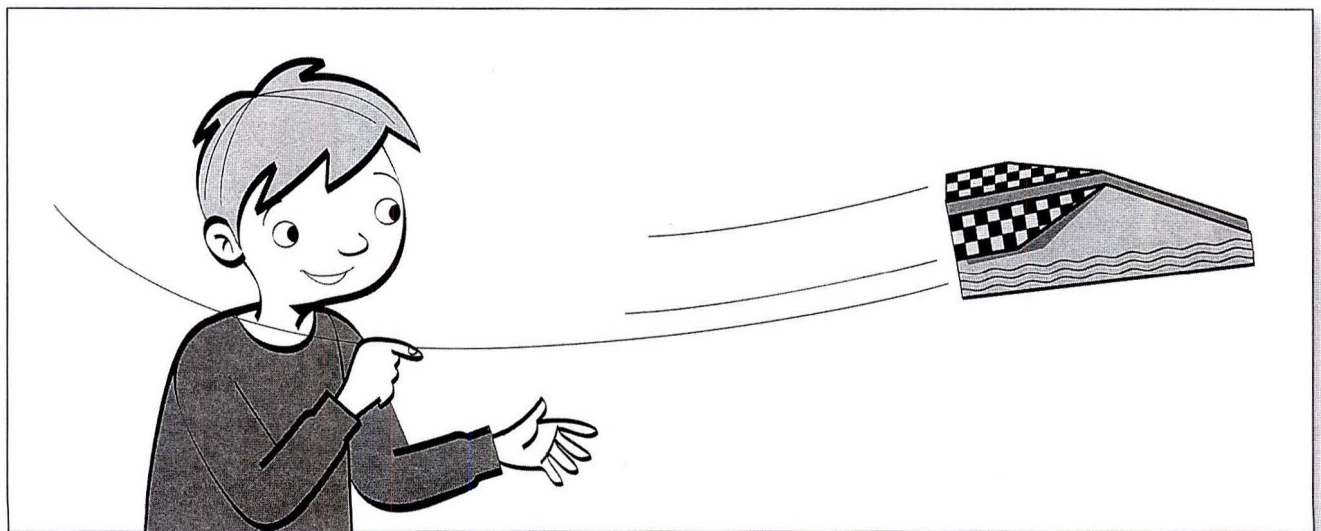
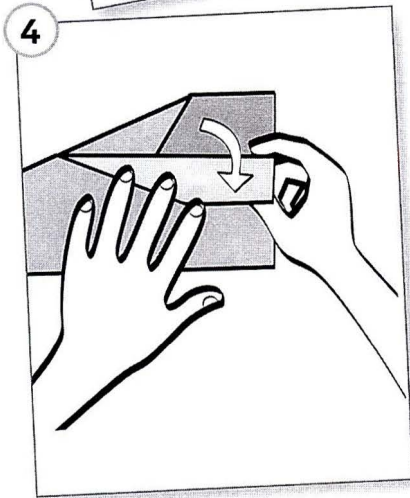
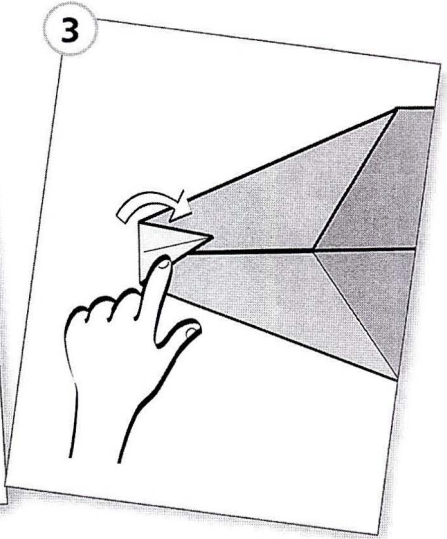
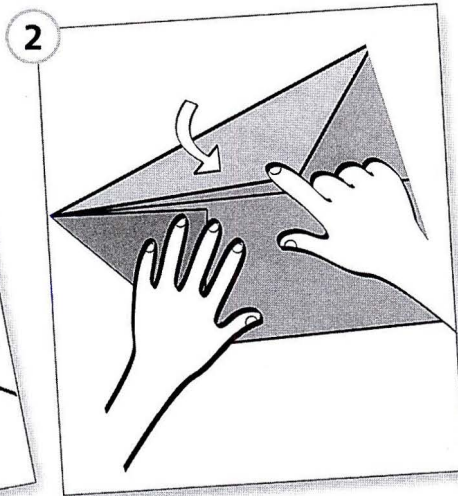
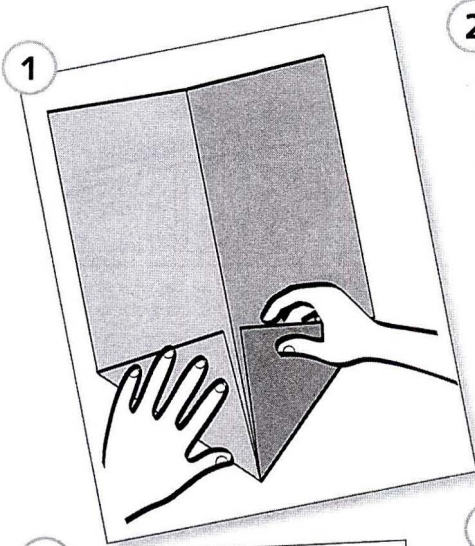

1 Say the words. Colour the circles.

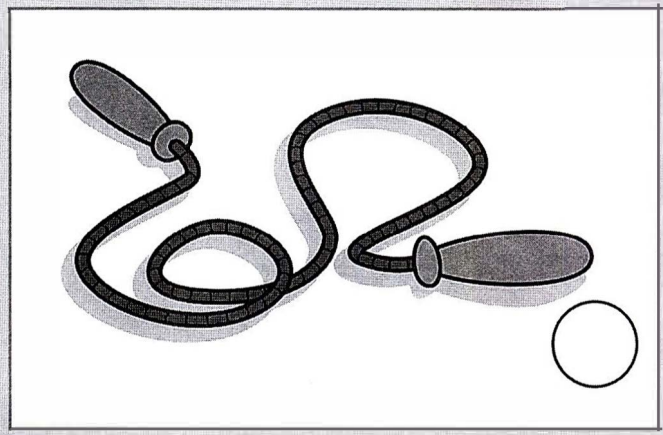
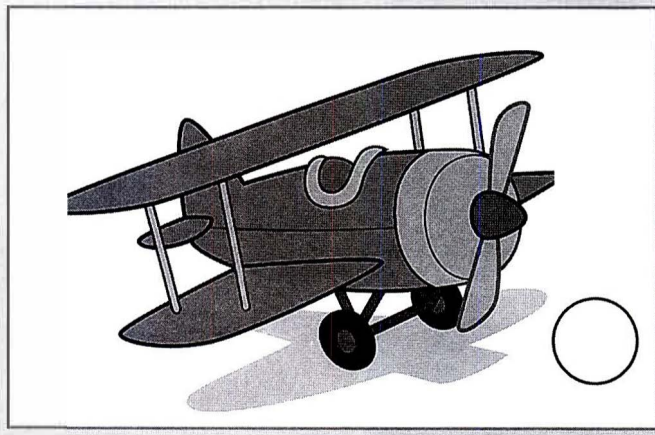
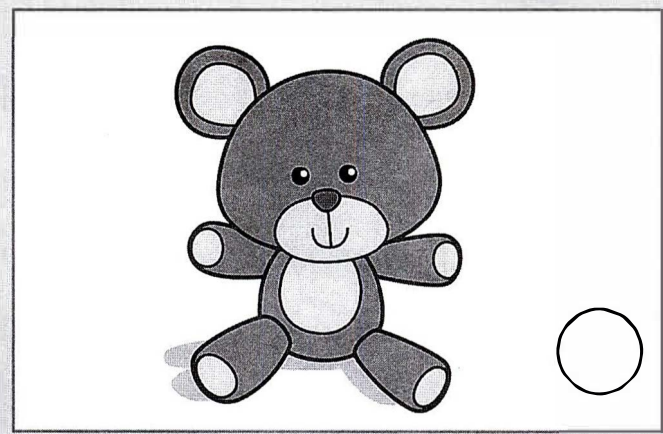
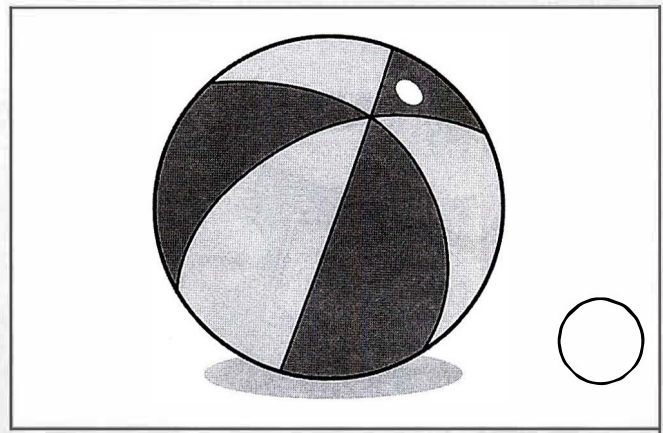
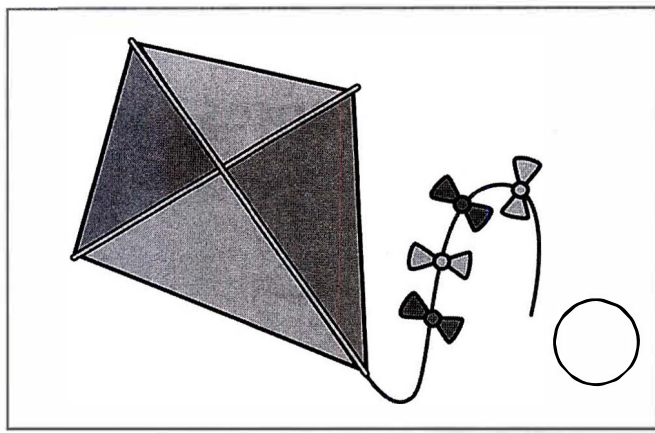

2 Draw faces. 😊 😐 ☹️

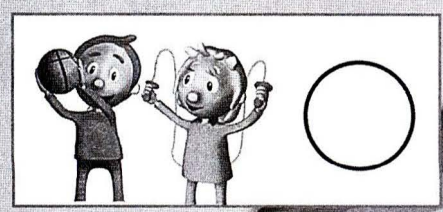
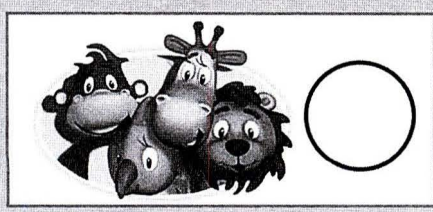
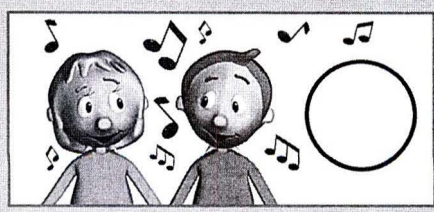

5

My house

1

Think! Match, colour and make sentences.

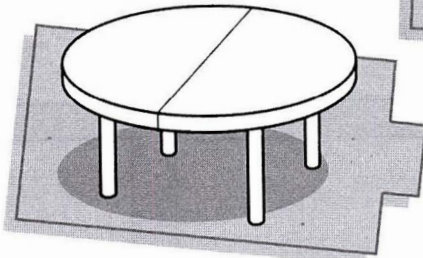
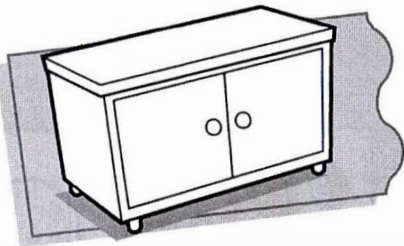
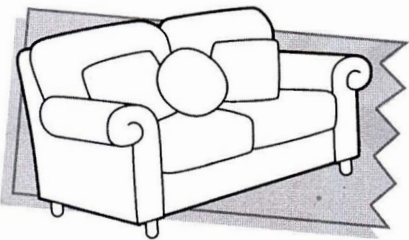
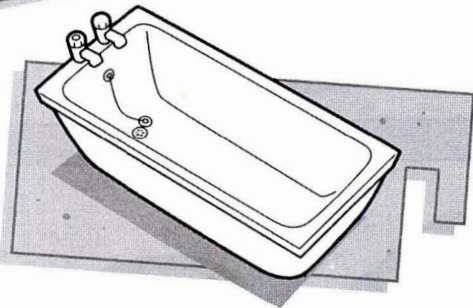
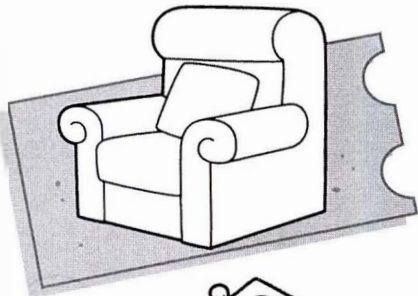
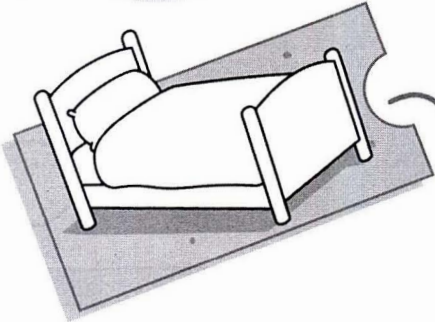

bath

sofa

cupboard

armchair

bed

table

1 CD2
05

Listen and circle.

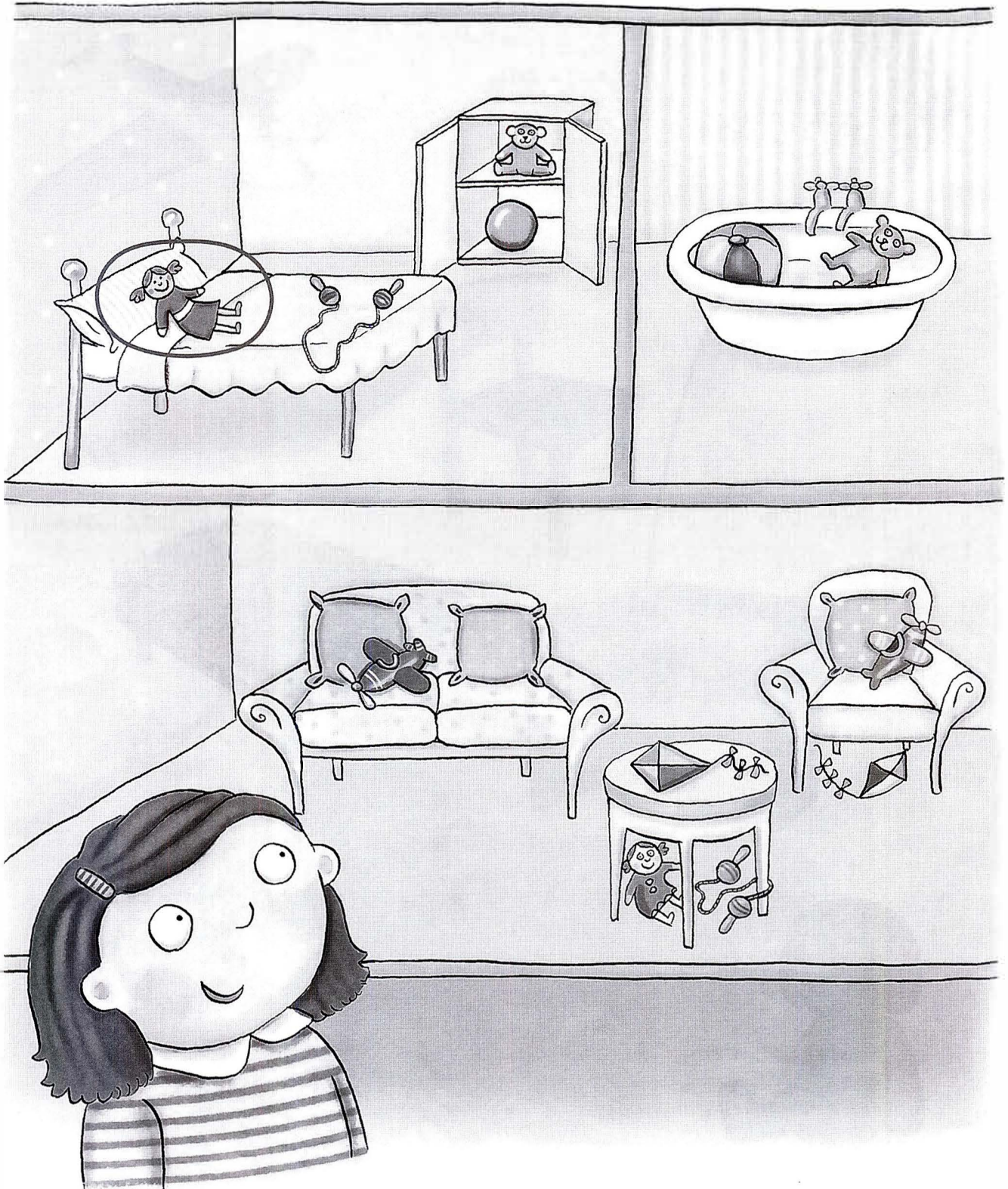

1 Draw lines.

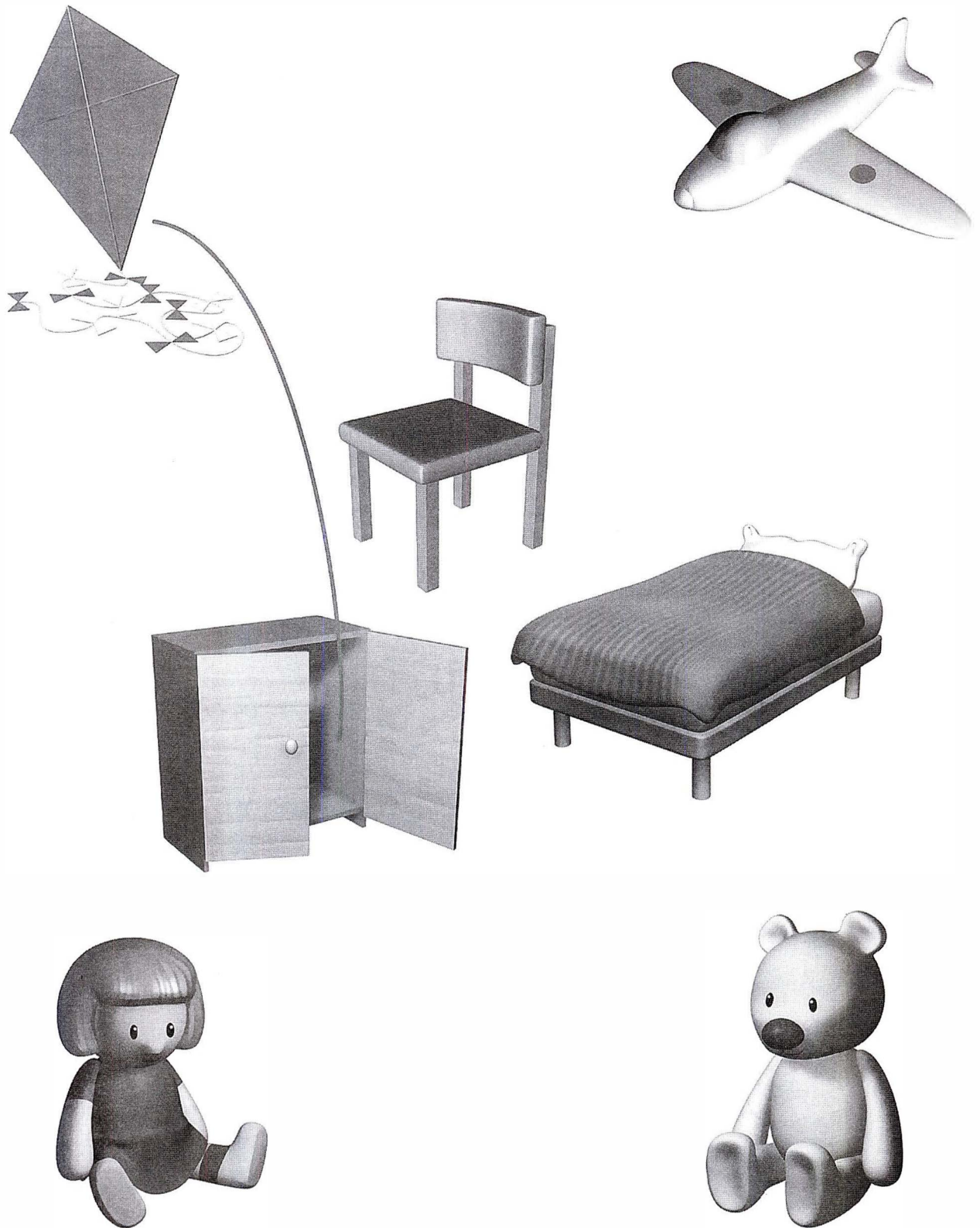

1 Find pairs and circle.

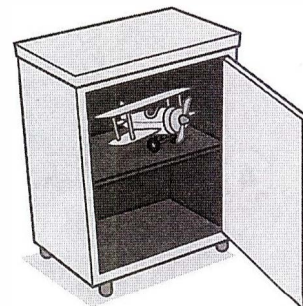
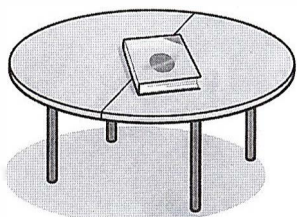
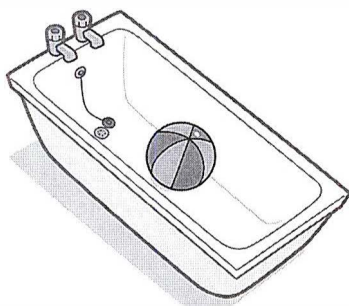
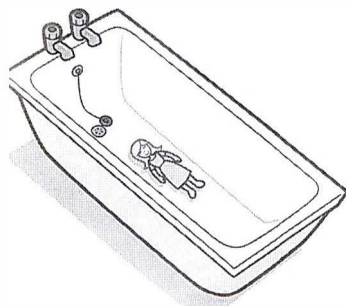
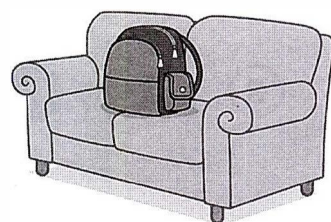
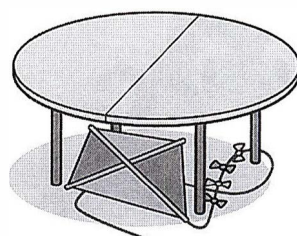
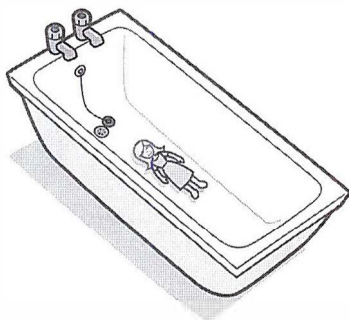
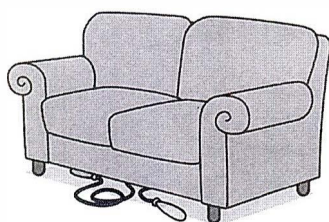
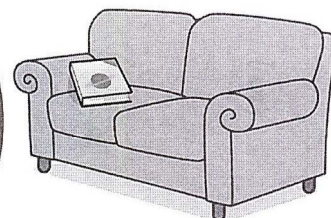
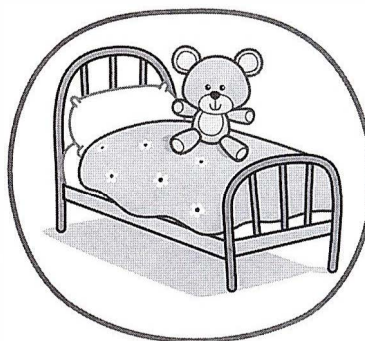
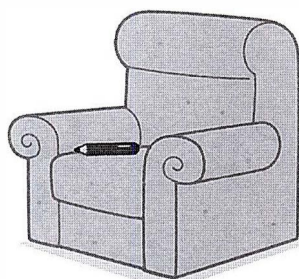
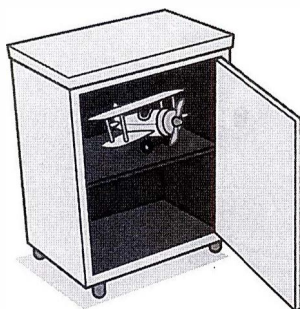
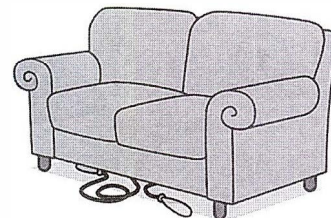
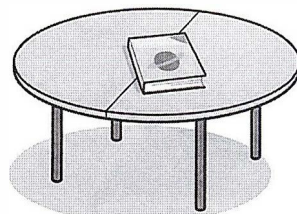
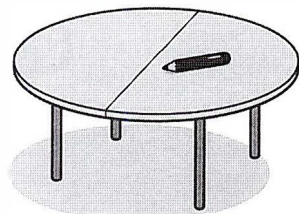
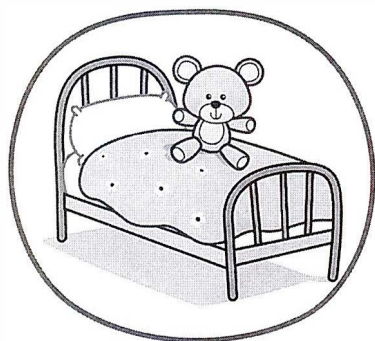

1  Listen and trace.

1

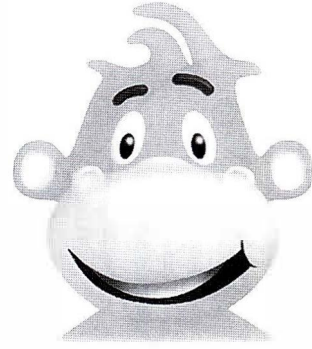
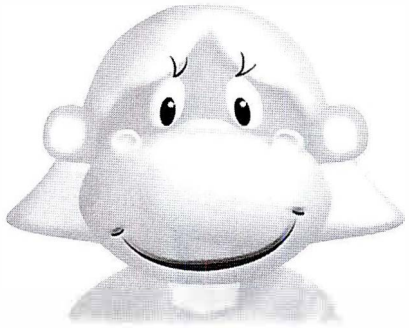

2

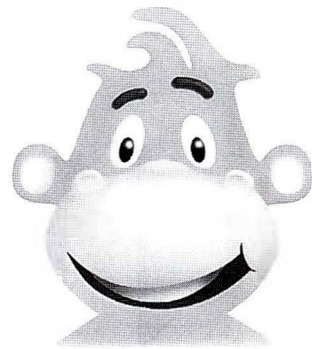
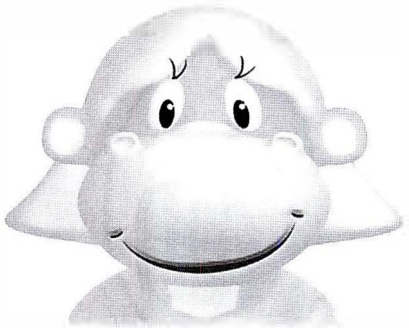

3

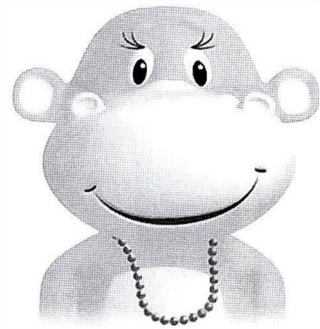

4

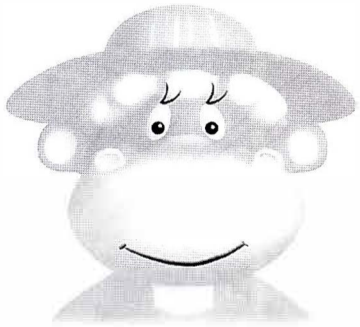

1 Think! Look and colour.

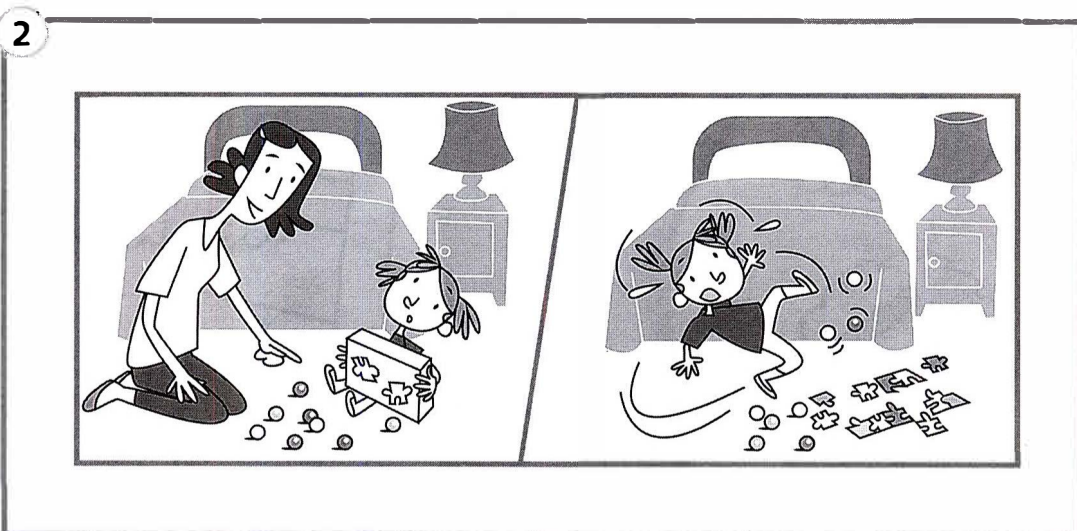
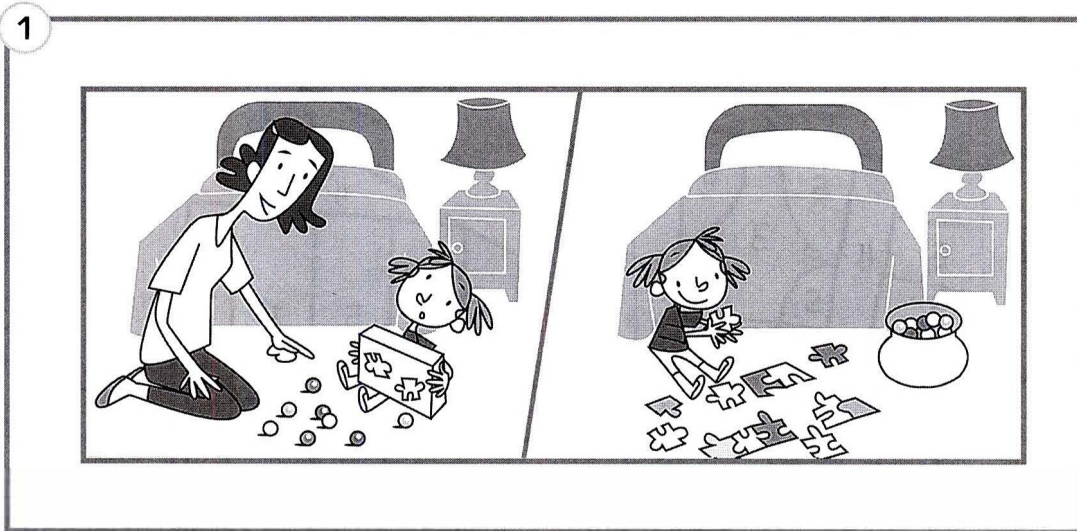
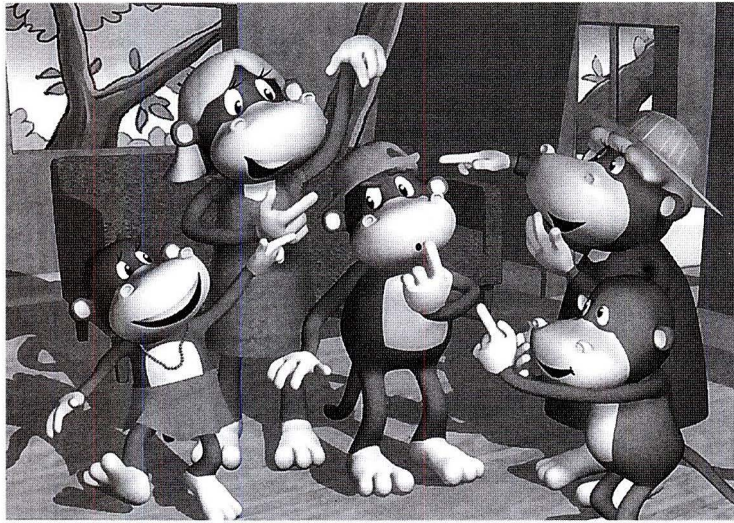

1 CD2
11 Listen and colour.

1	2	3	4	5	6
----------	----------	----------	----------	----------	----------

2 Think! Look and colour.



1 Think! Follow the path. Count and circle.

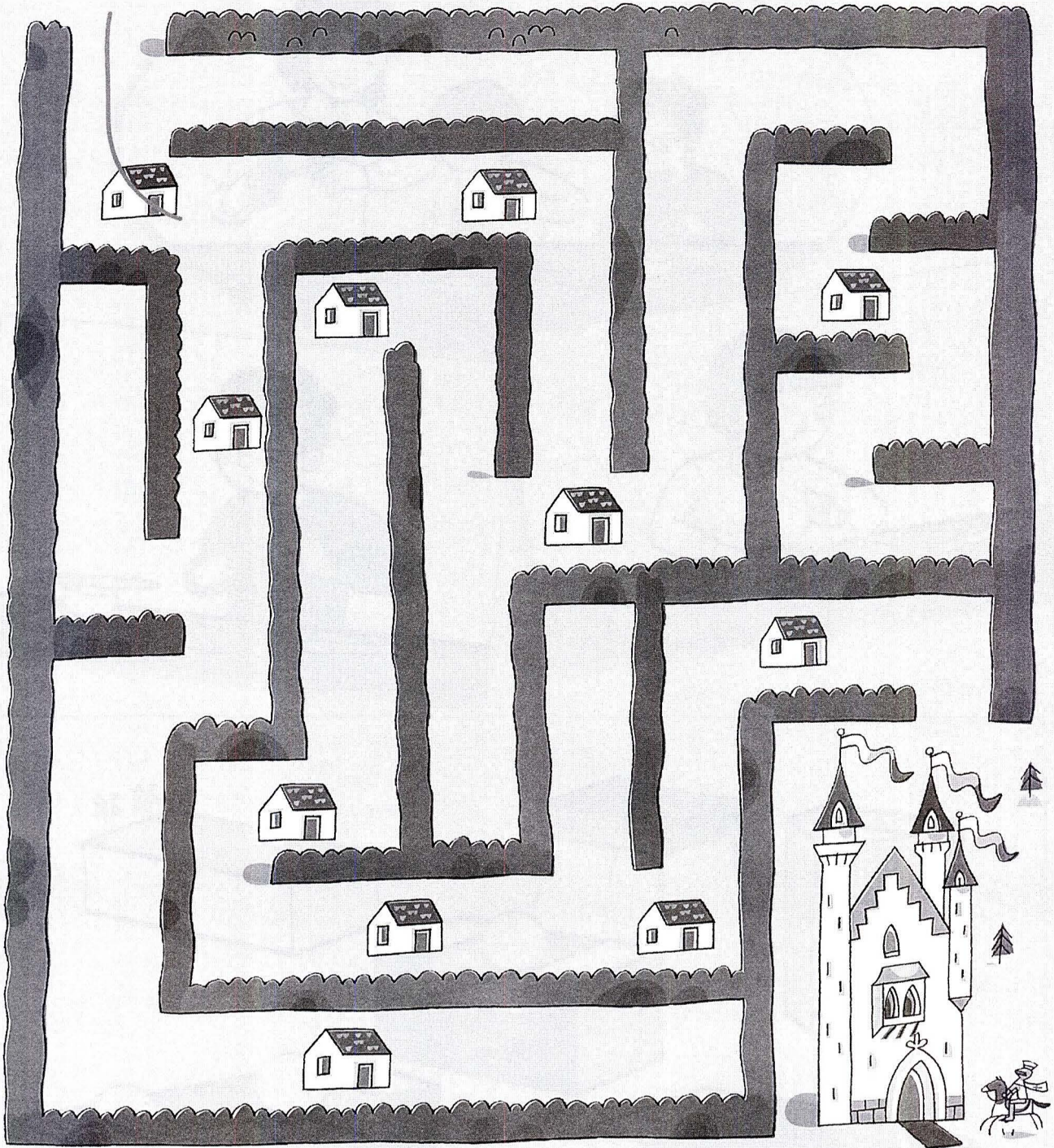

1

2

3

4

5

6

7

8

9

10

1 Make dolls' furniture.

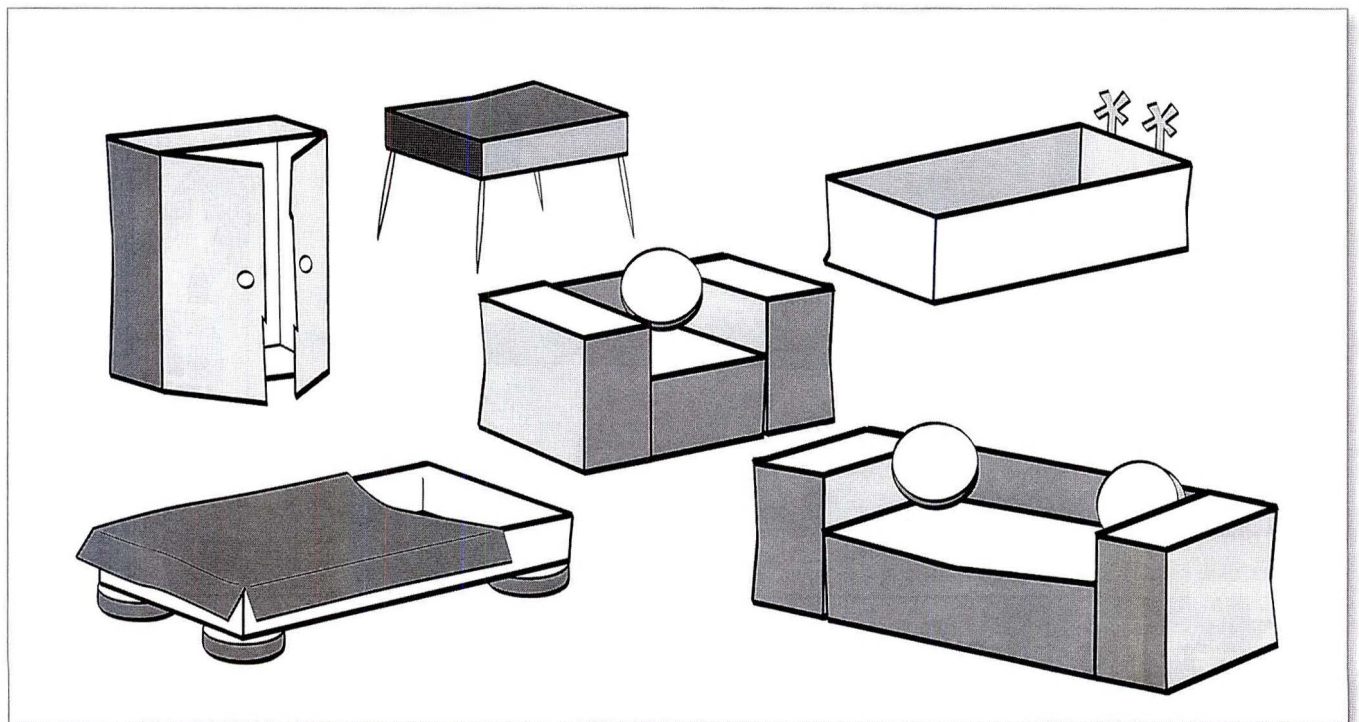

1 Say the words and trace. Colour the circles.

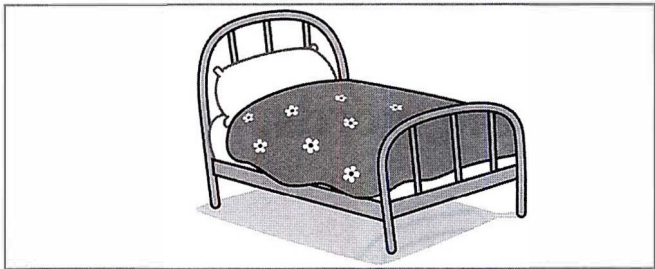

bed

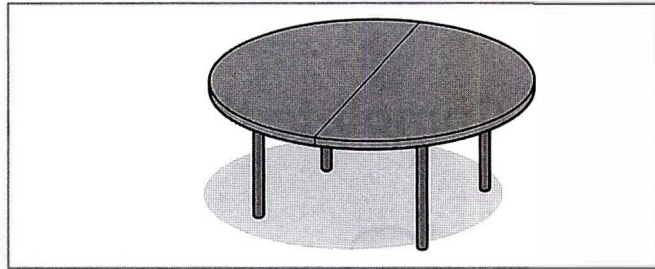

table

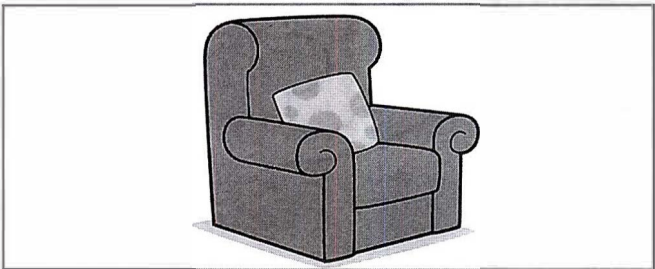

armchair

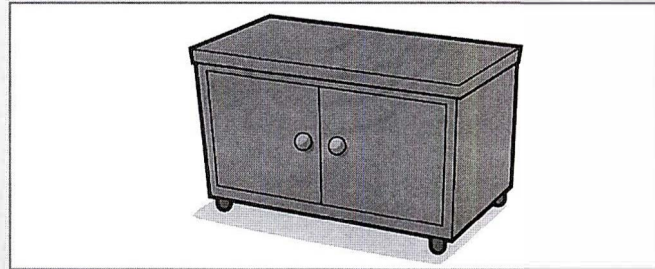

cupboard

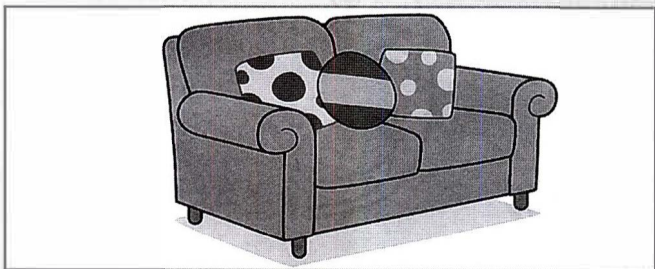

sofa

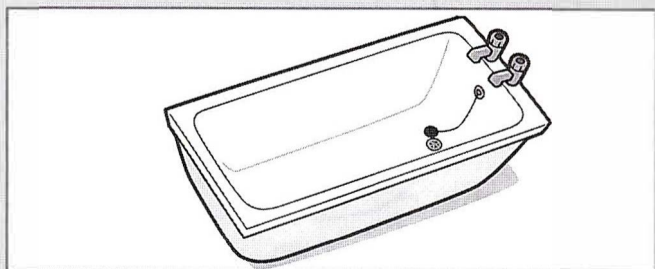

bath

2 Draw faces. 😊 😐 😞

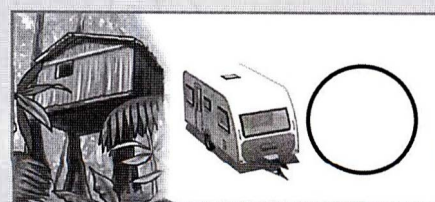
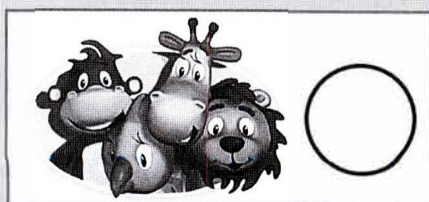

6

On the farm

1 Complete the animals. Say the words.

1



dog

2

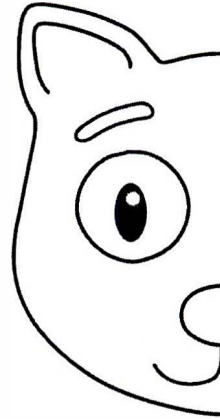

cat

3



sheep

4



cow

5



rabbit

6



horse

1 Draw your favourite animals.



Listen, point and say the words.

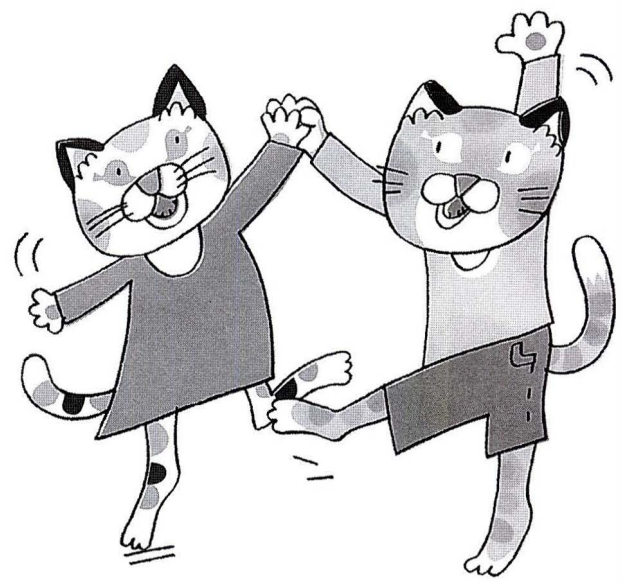
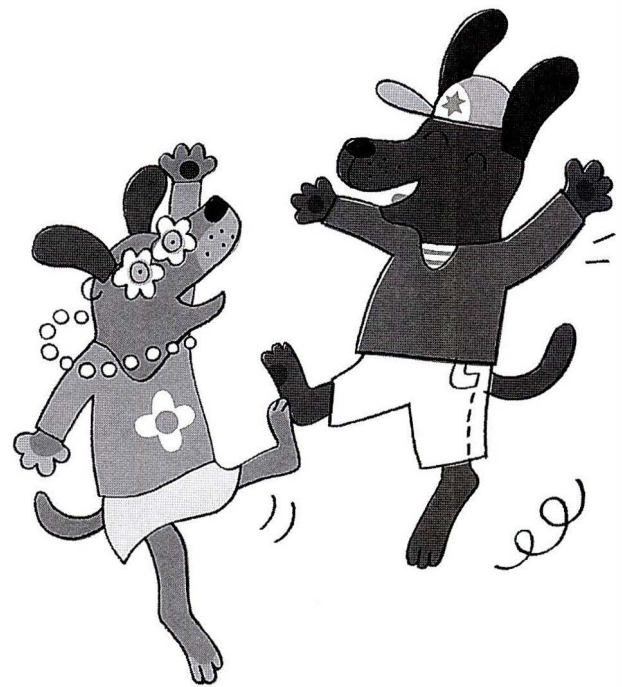

1 CD2
20

Listen and colour. Follow the paths.



My favourite colour is (blue) / (toys) are (planes).

Listen and trace.

1

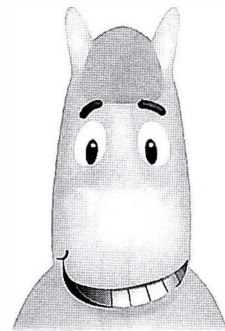
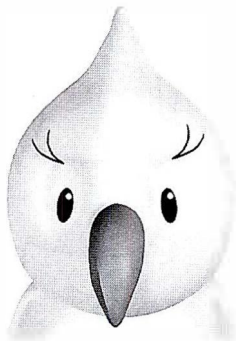

2

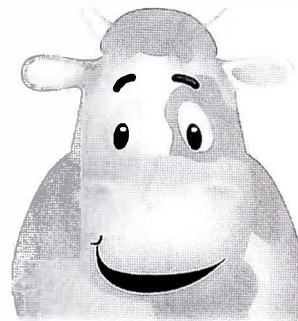
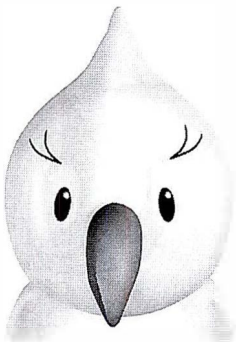

3

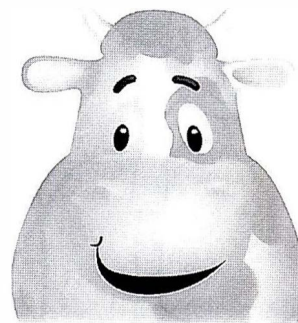
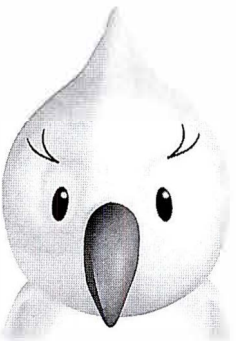

4

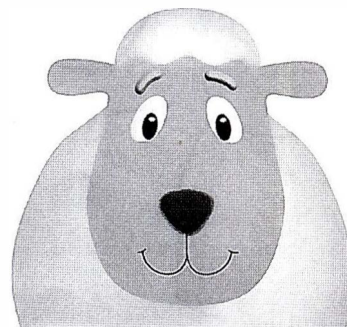
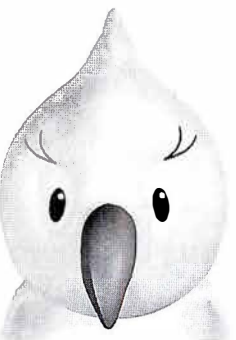

1 Think! Look and colour.

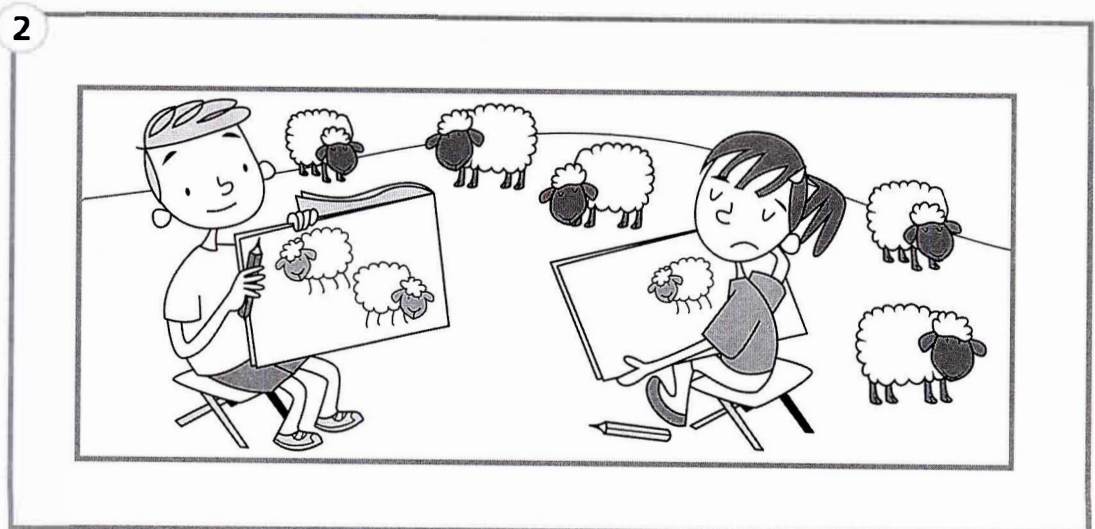
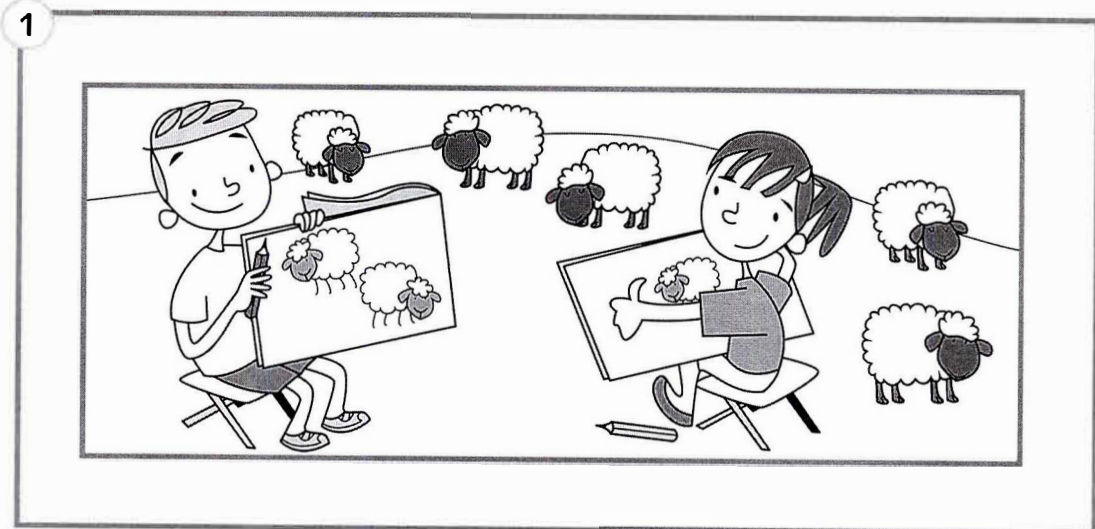
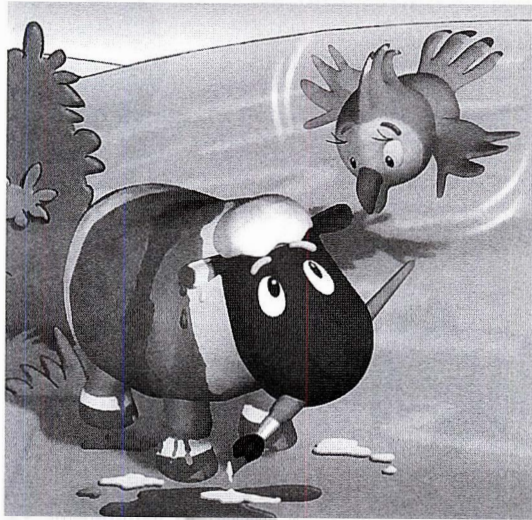

1 Match. Where do they live?

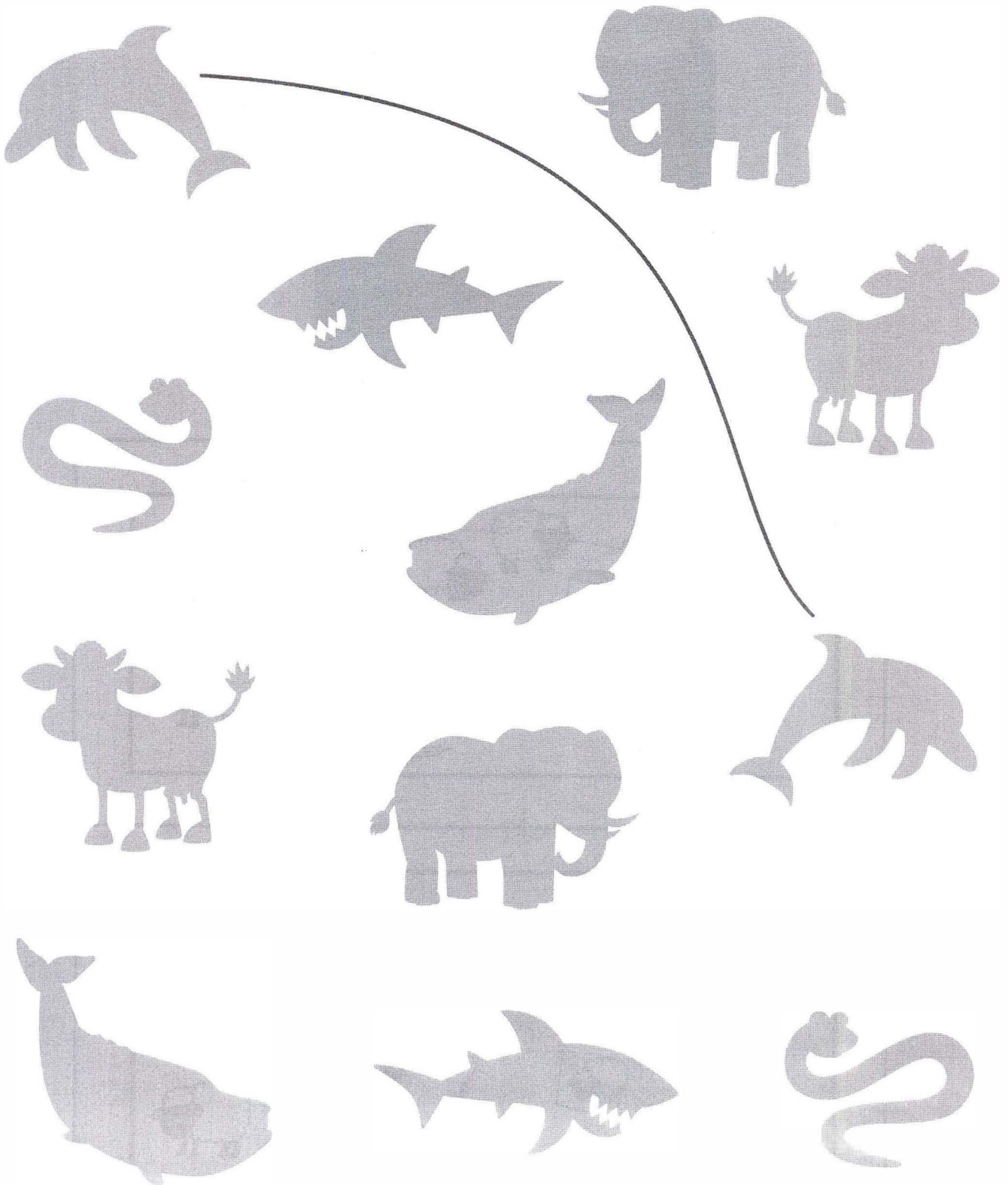

1

Think! Look and cross out.

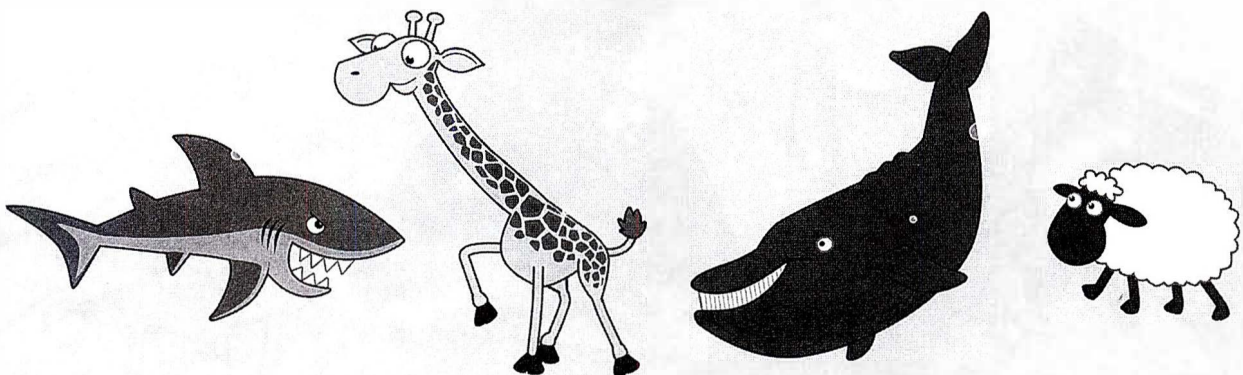
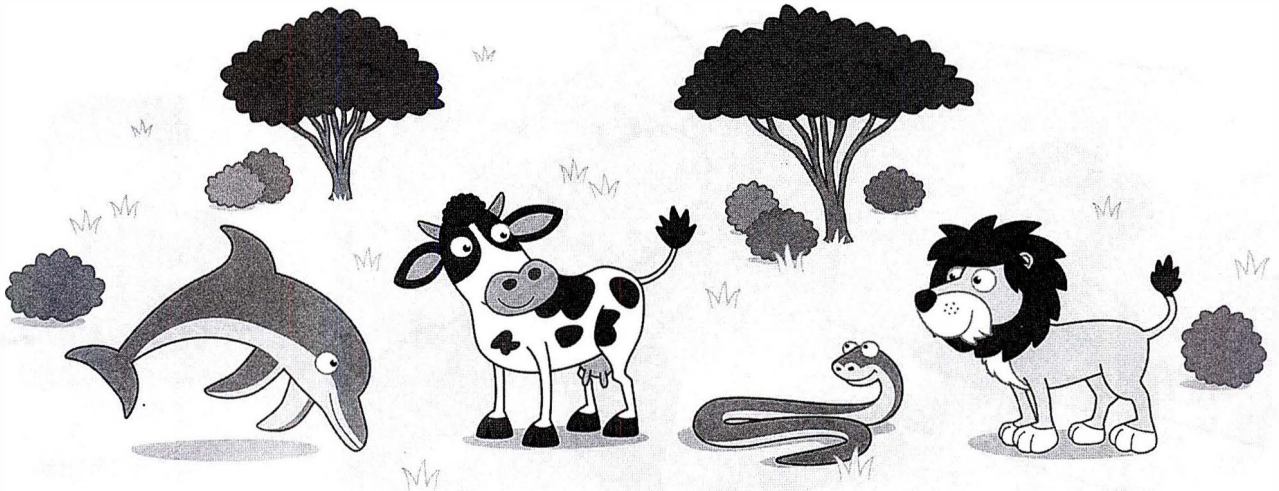
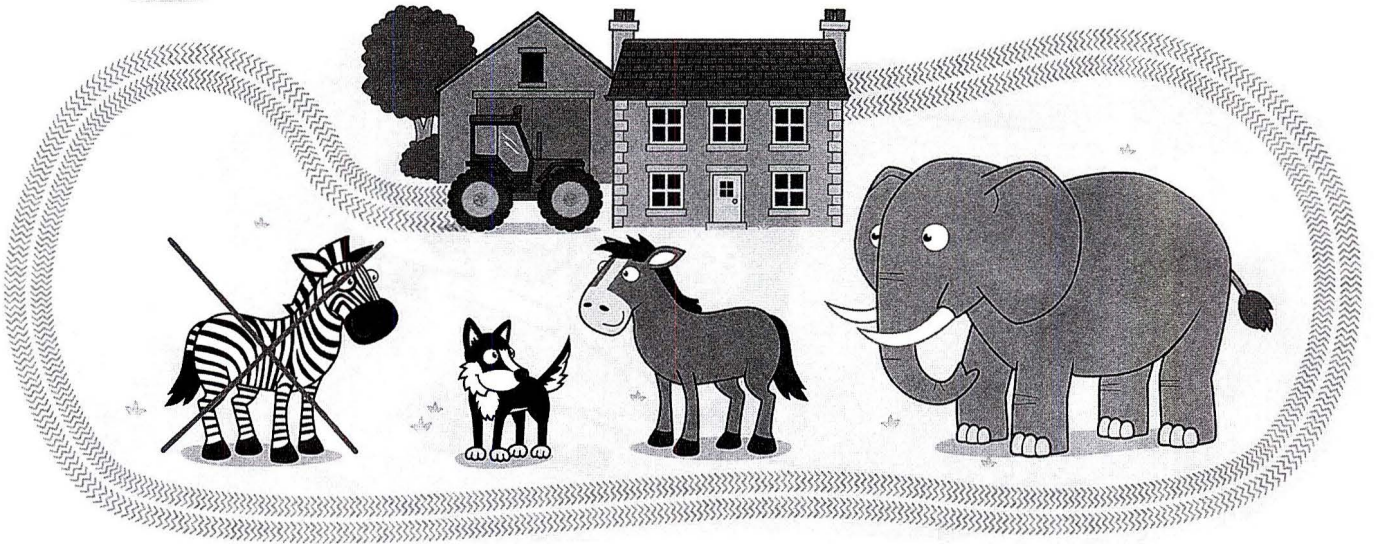

1

Make a woolly sheep.

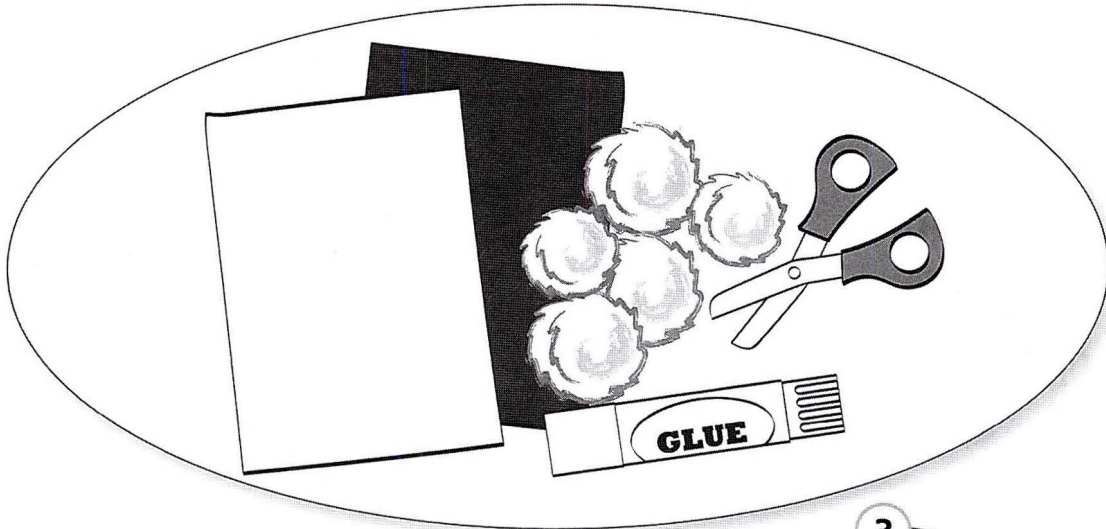

1

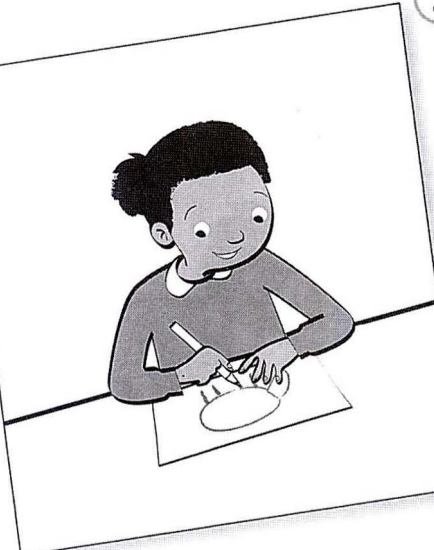

2

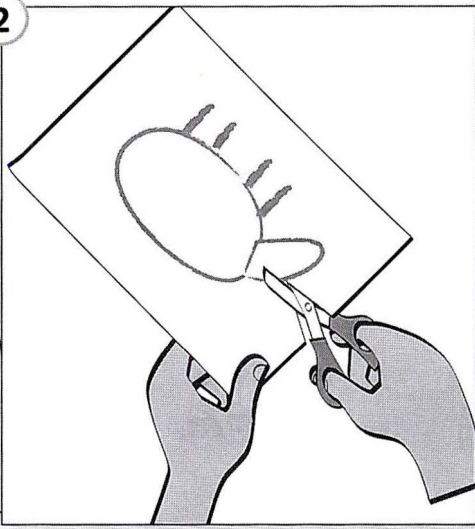

3

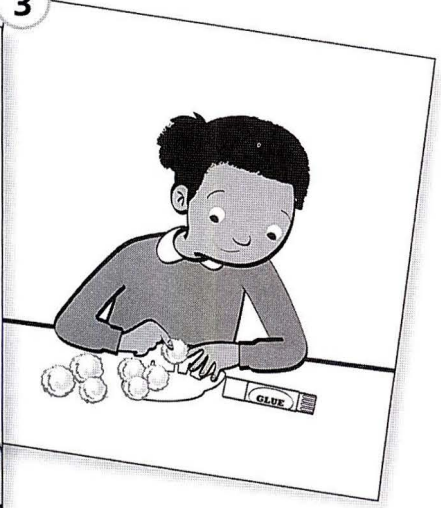

4

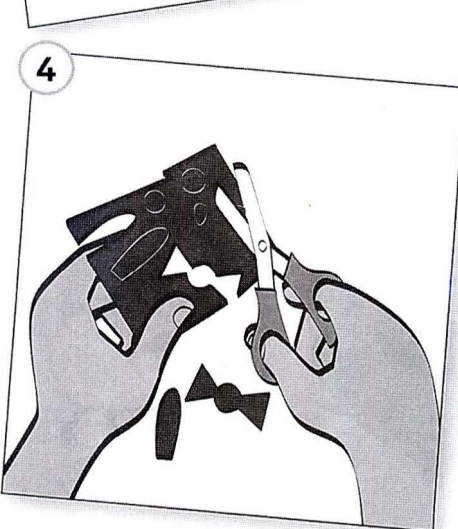

5

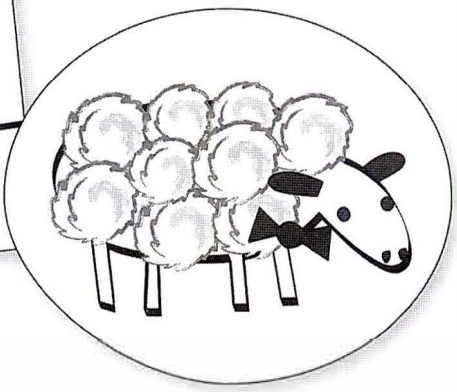

1 Say the words and trace. Colour the circles.

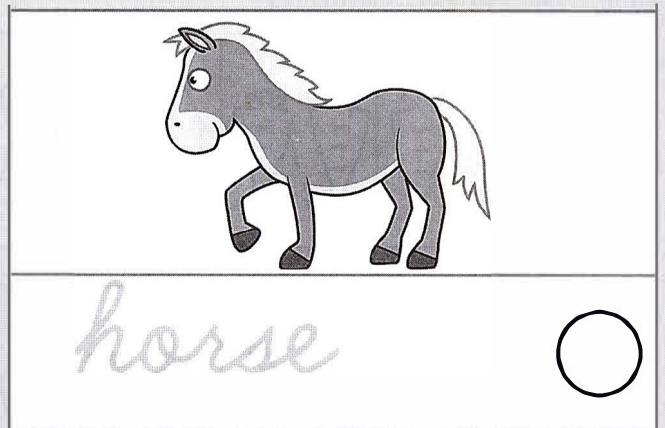
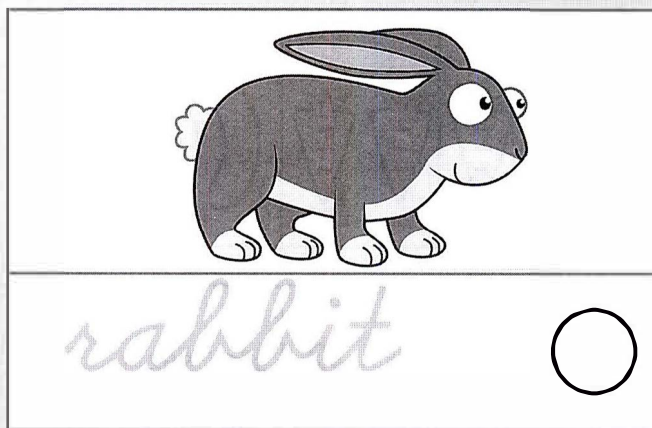
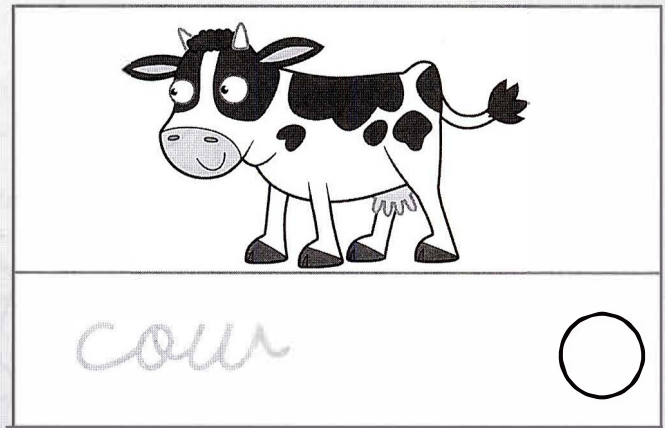
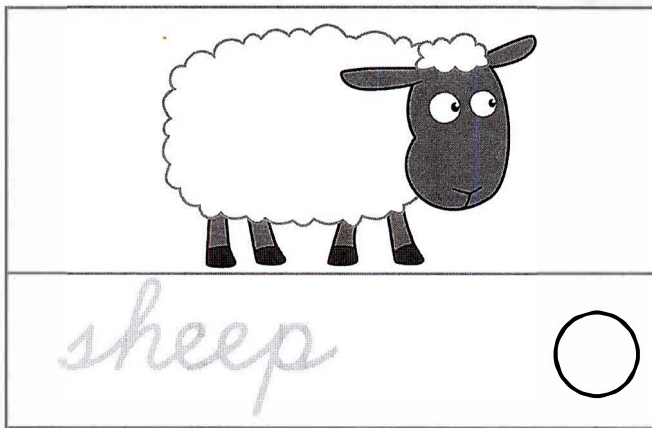
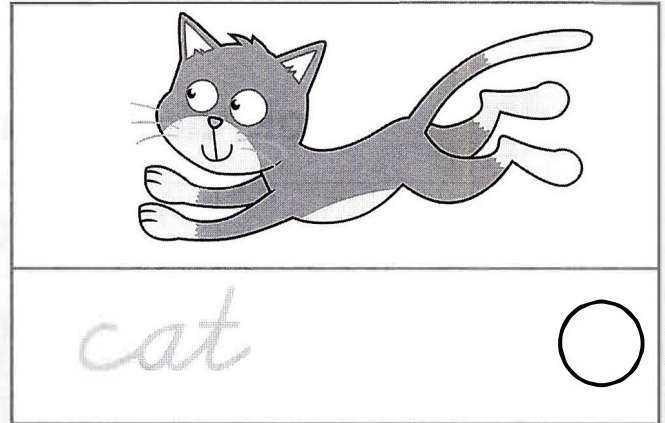
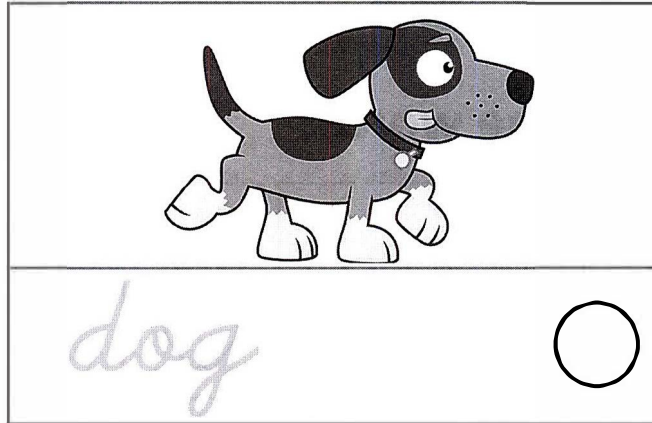

2 Draw faces. 😊 😐 😞

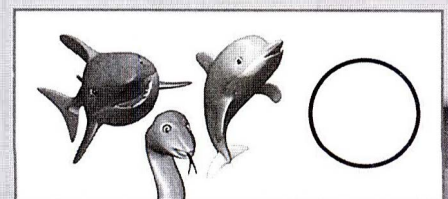
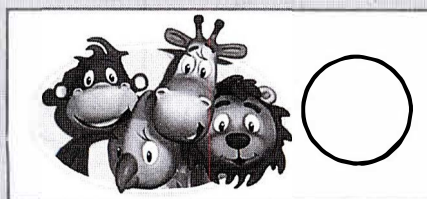
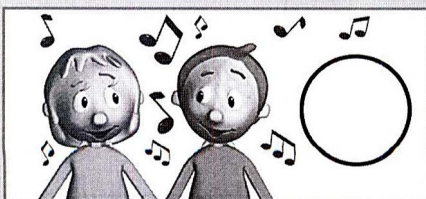

7

I'm hungry!

1 Think! Look, draw and say the words.

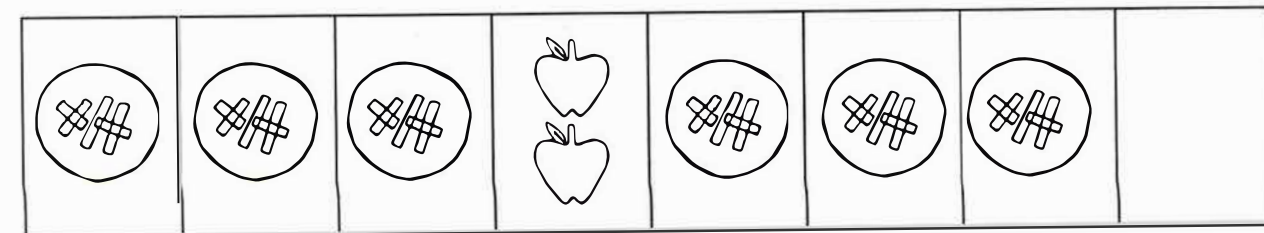
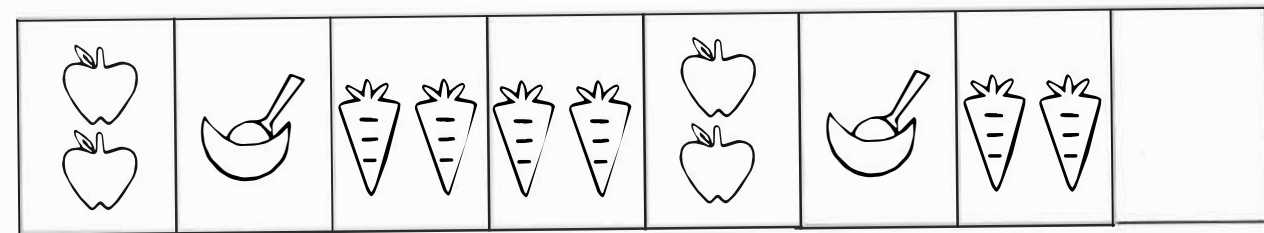
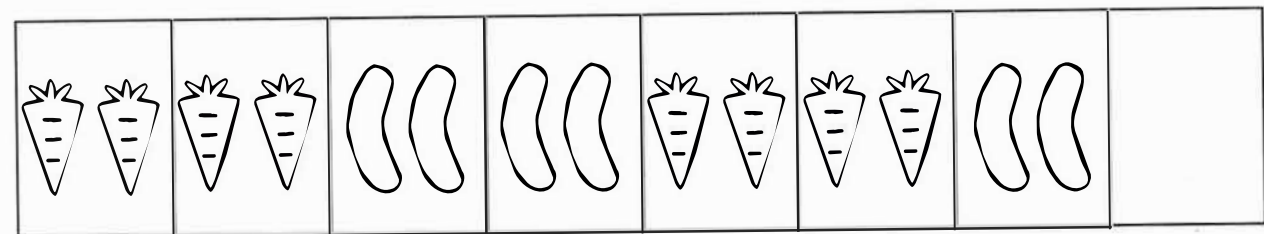
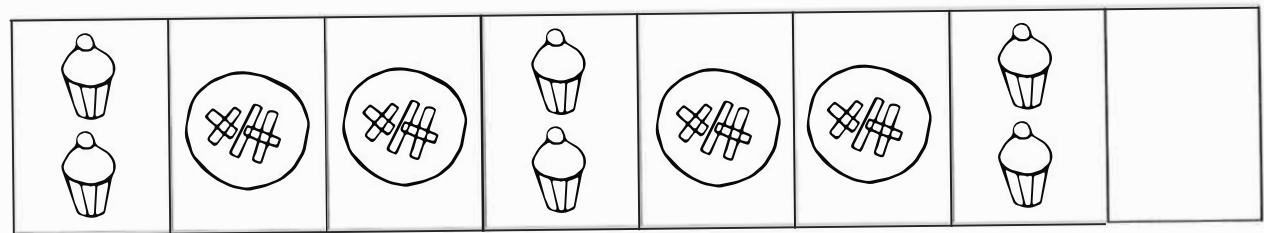
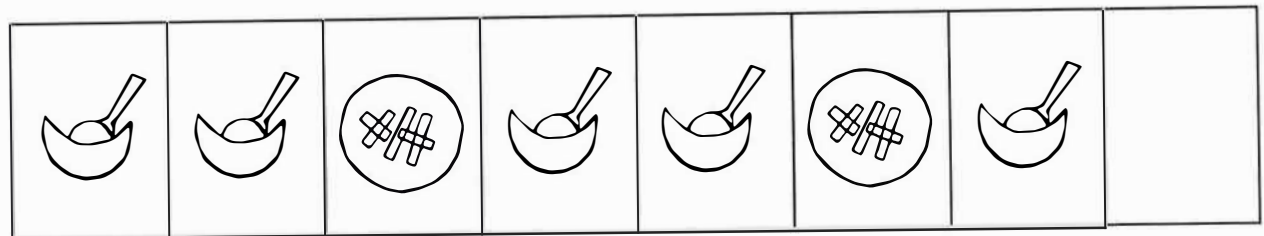
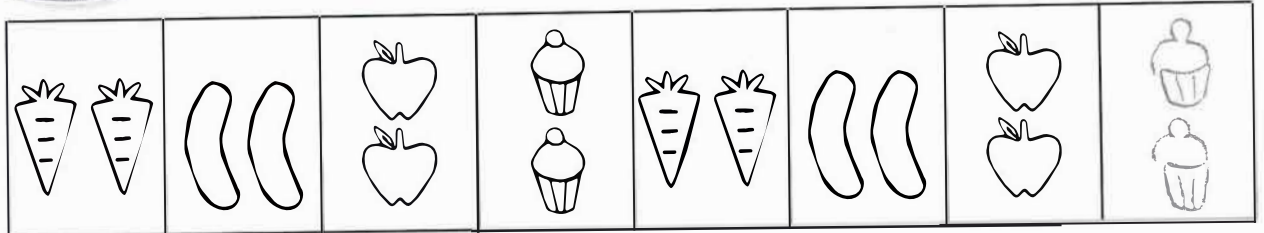

1 CD2
28 Listen and match.

1

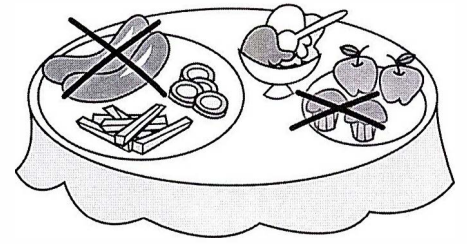
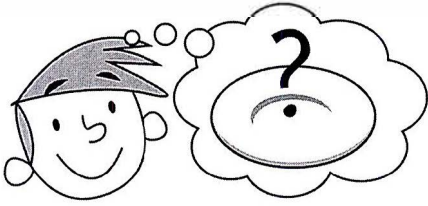

2

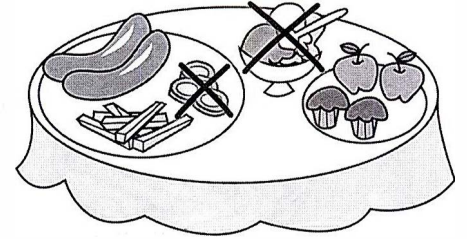
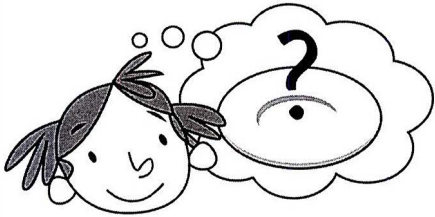

3

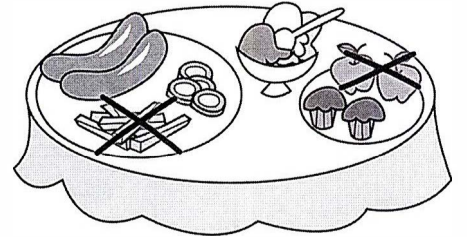
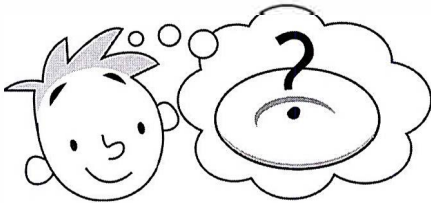

4

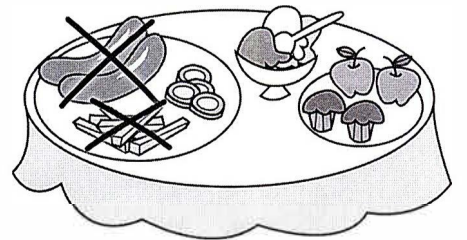
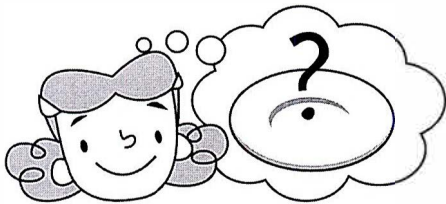

2 Draw your favourite food.

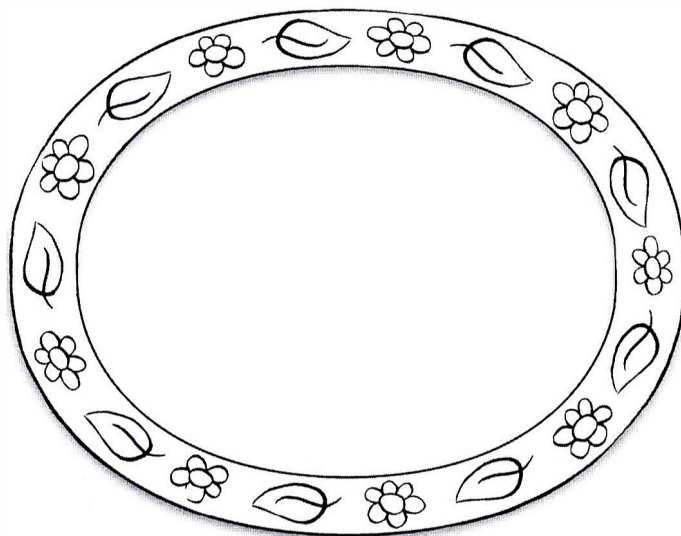

1

Draw.

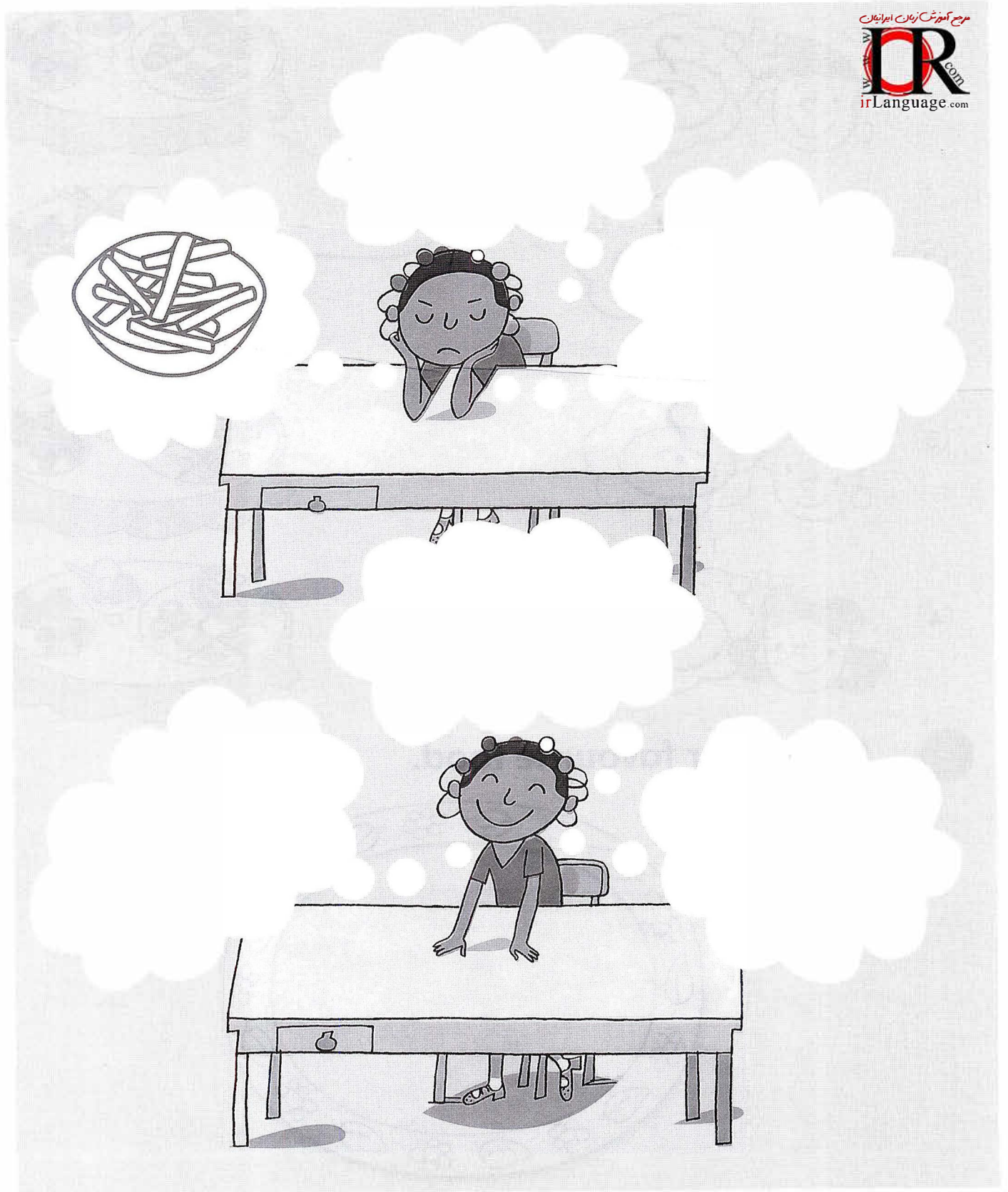

1

Draw faces. 😊 ☹️ Tell your friend and draw.

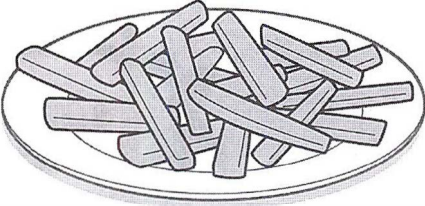
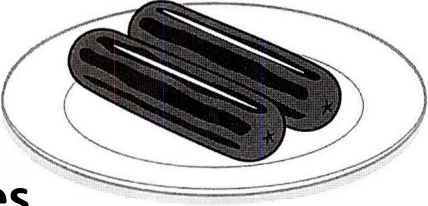
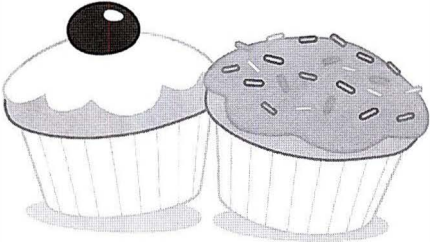
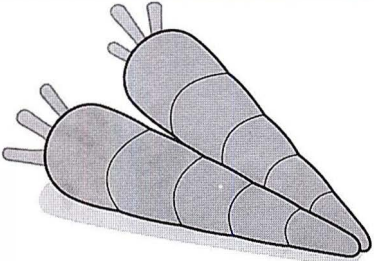
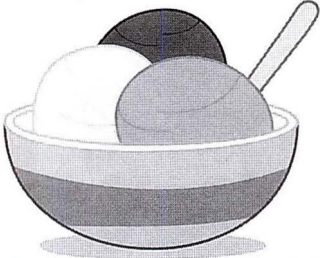
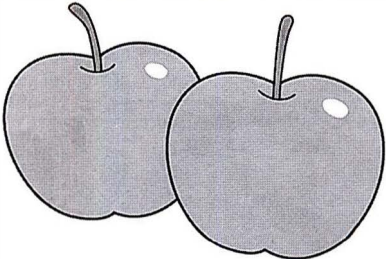
<p>chips</p> 		
<p>sausages</p> 		
<p>cakes</p> 		
<p>carrots</p> 		
<p>ice cream</p> 		
<p>apples</p> 		

Listen and trace.

1

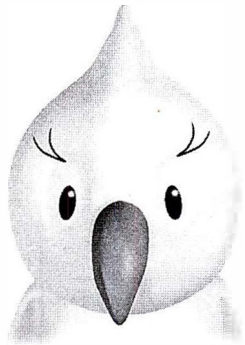

2

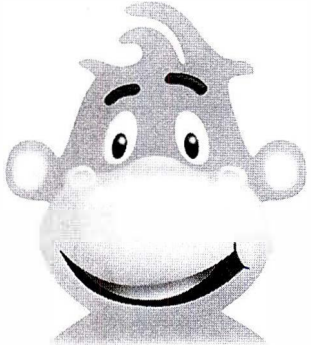

3

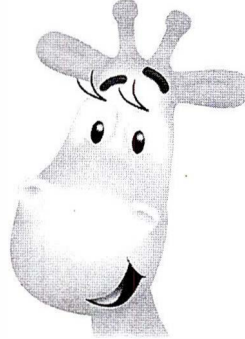

4

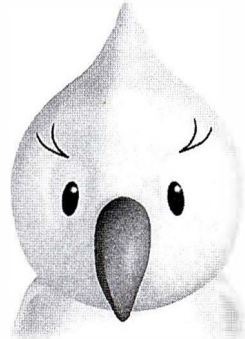

1 Think! Look and colour.

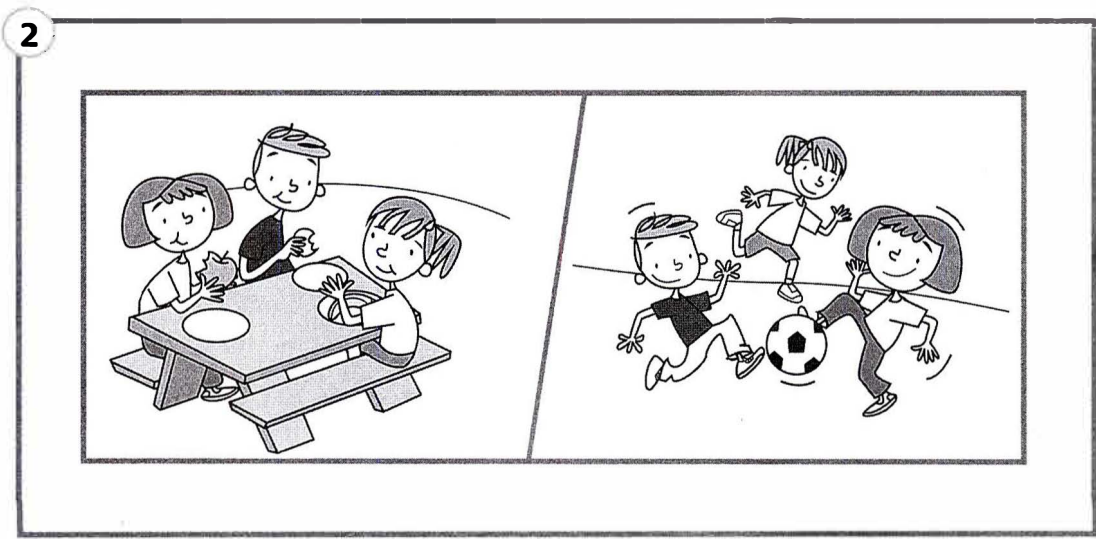
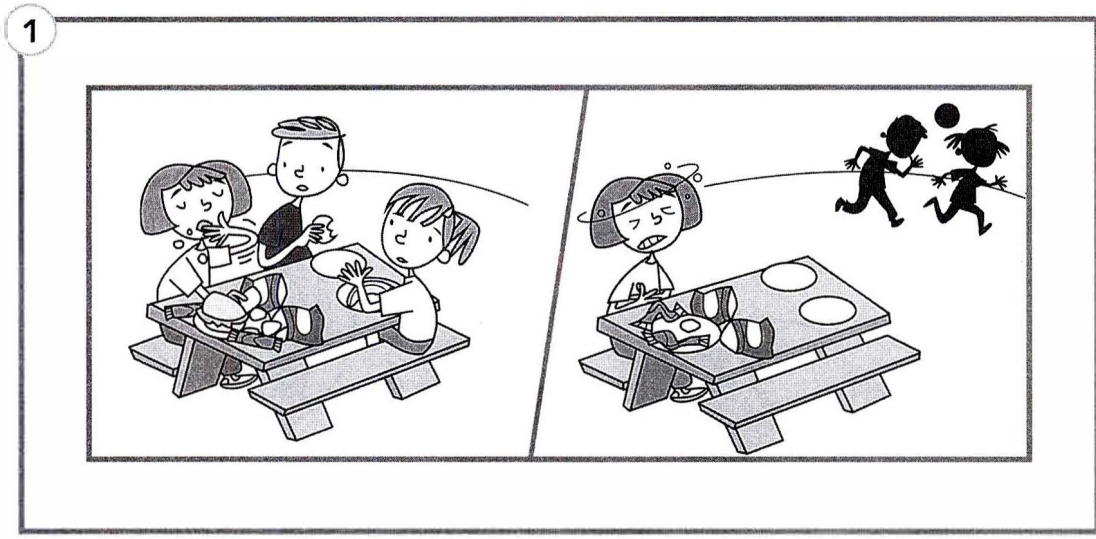
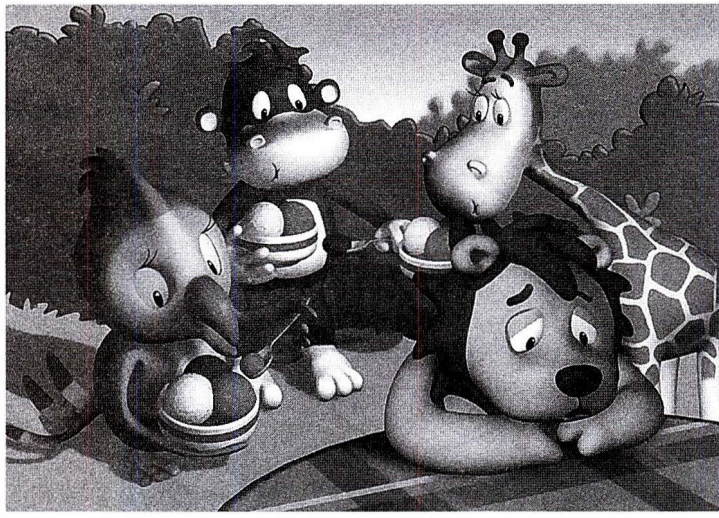

1 Draw lines. Describe the meals.

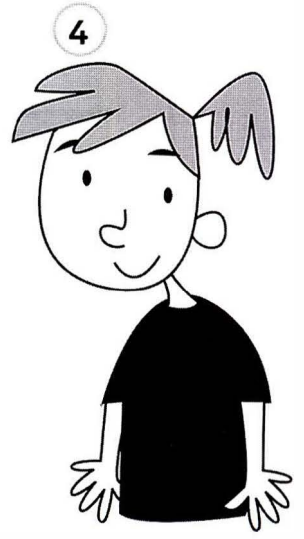
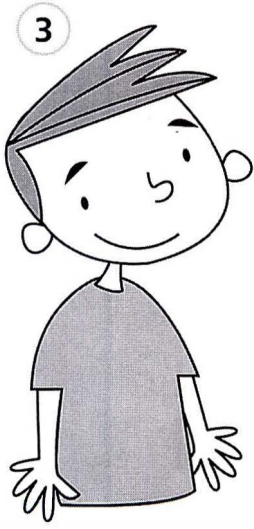
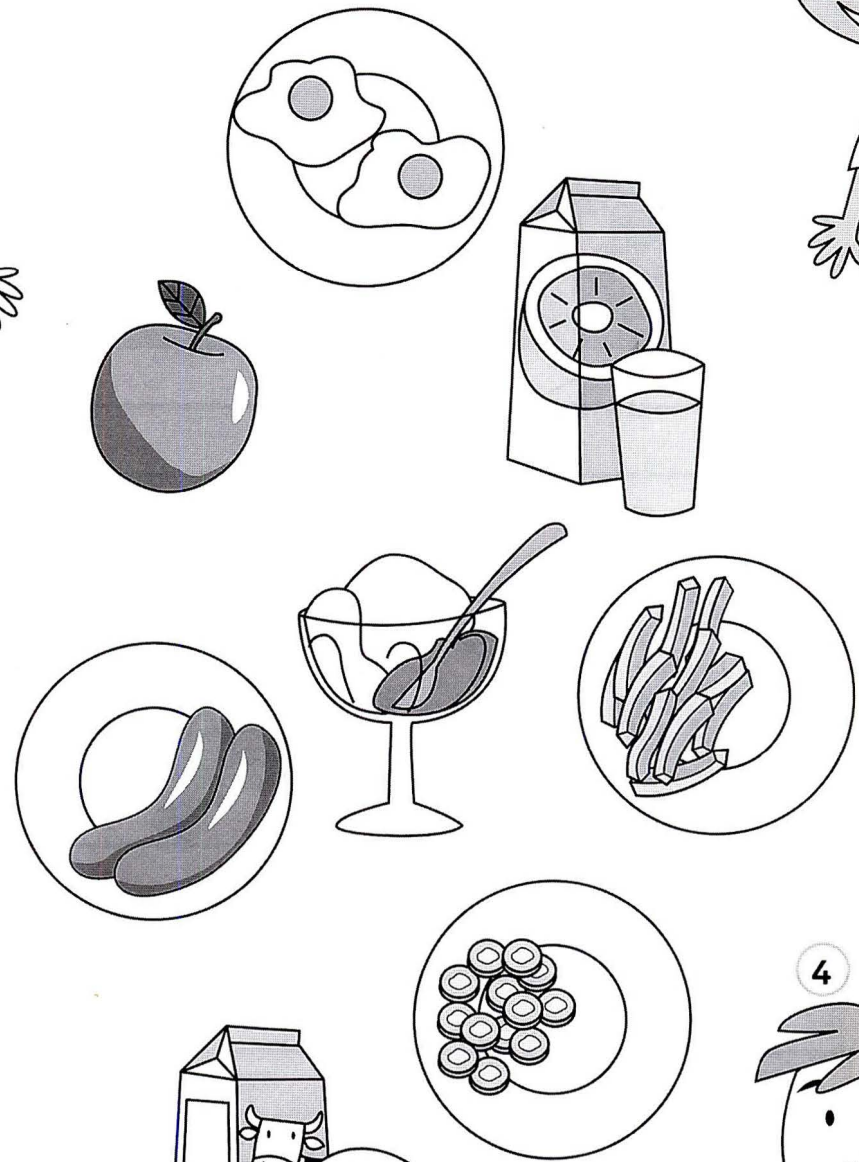
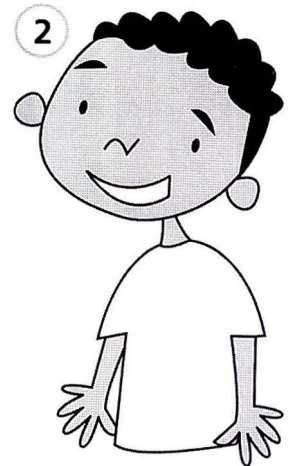
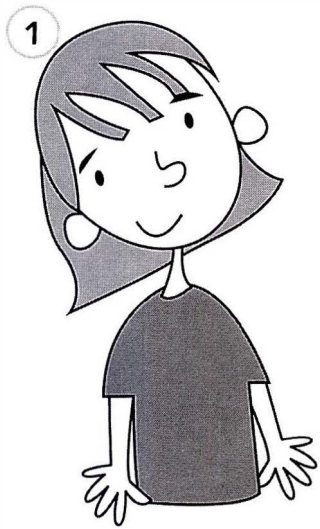

1 Think! Look and circle.

1

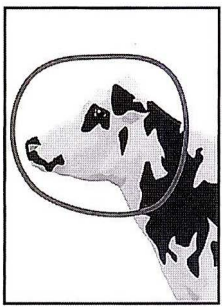
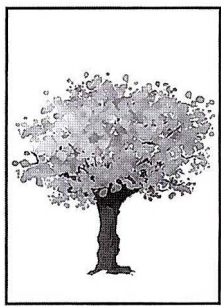
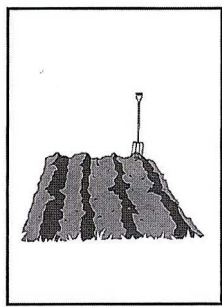
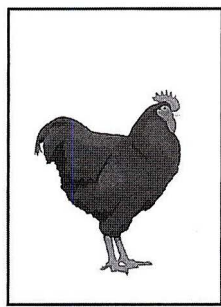
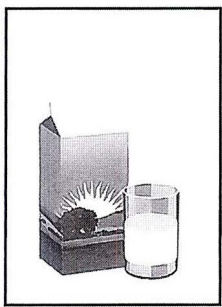

2

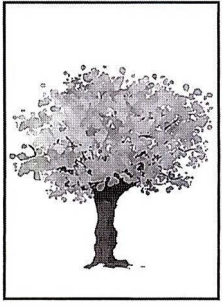
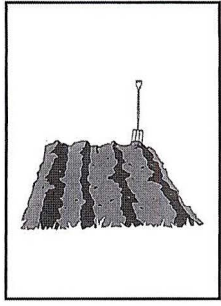
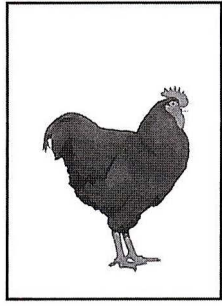
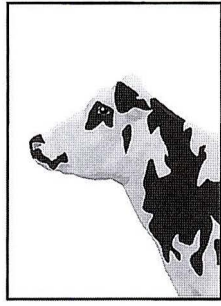
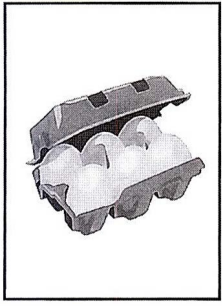

3

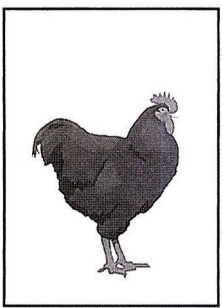
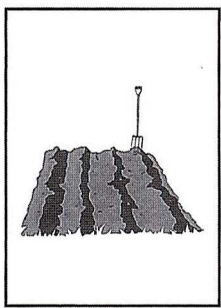
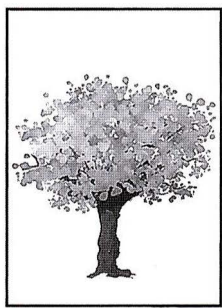
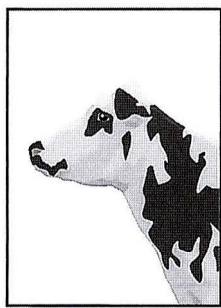
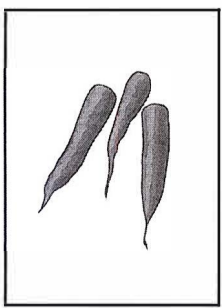

4

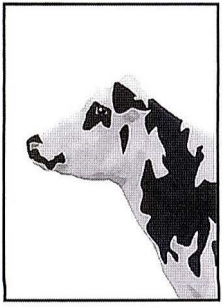
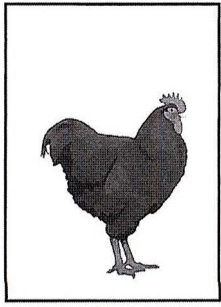
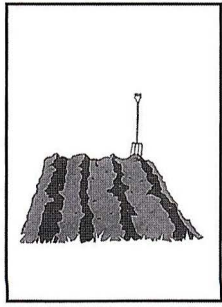
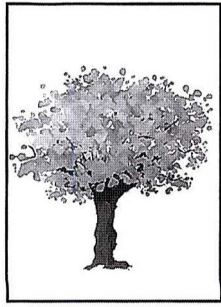
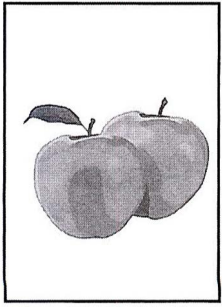

1 Make biscuit faces.

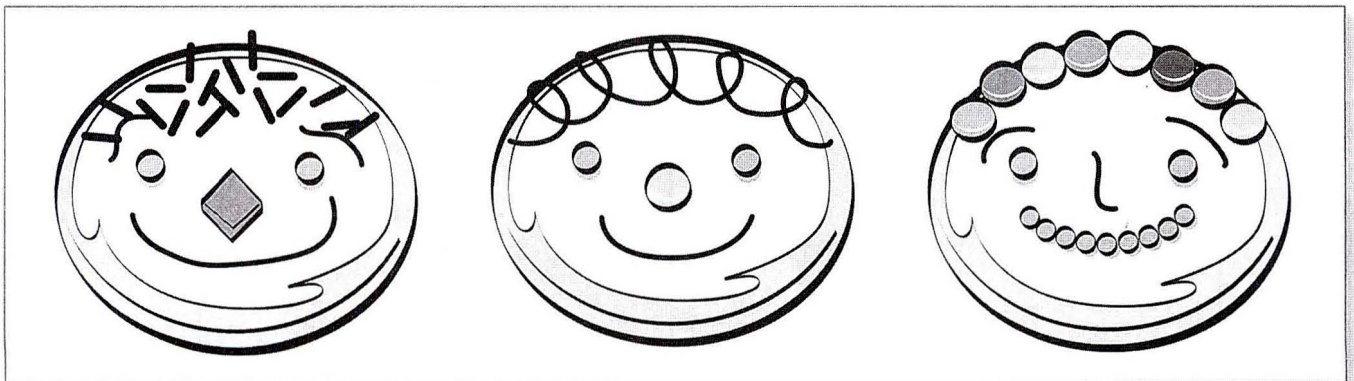
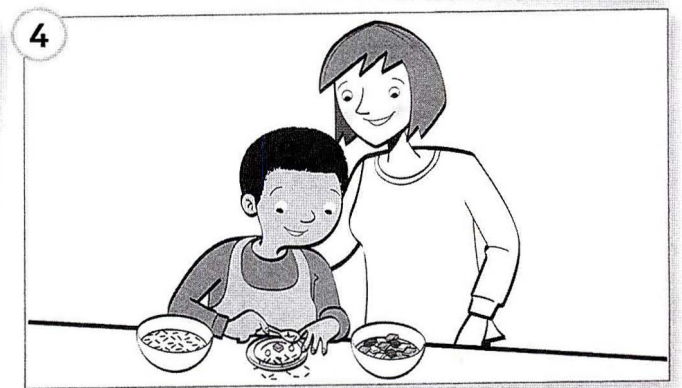
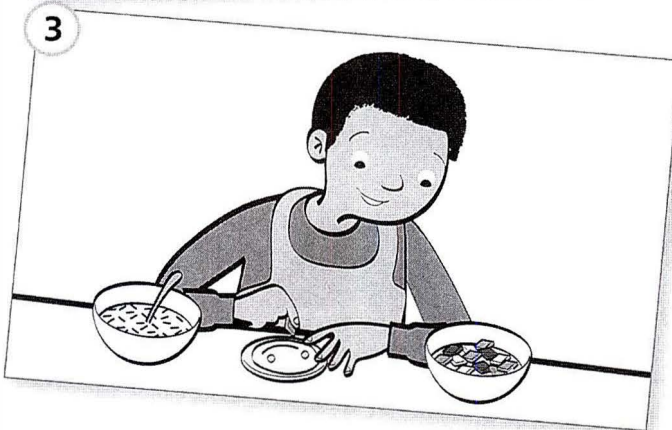
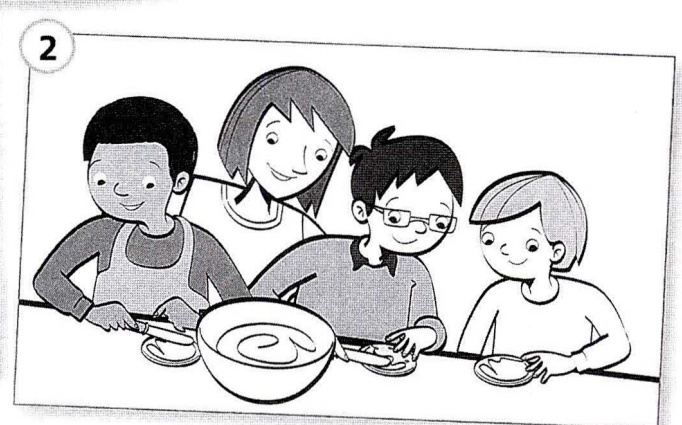
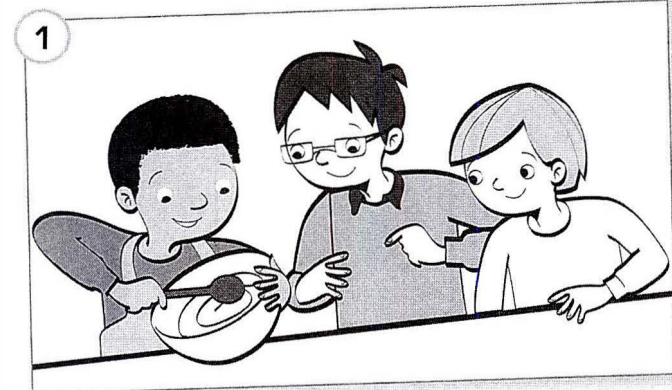
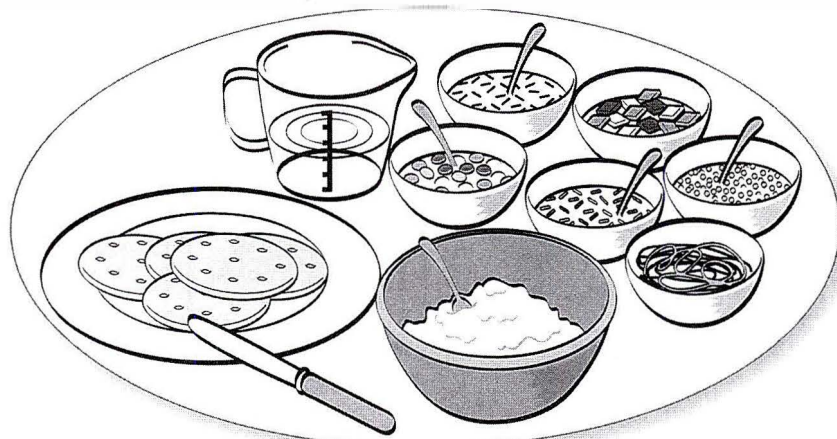

1 Say the words and trace. Colour the circles.

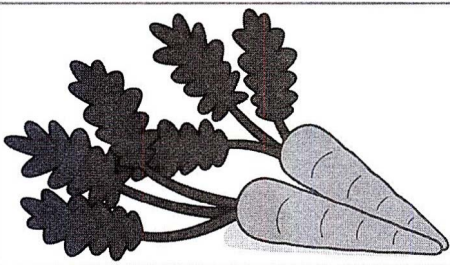

carrots

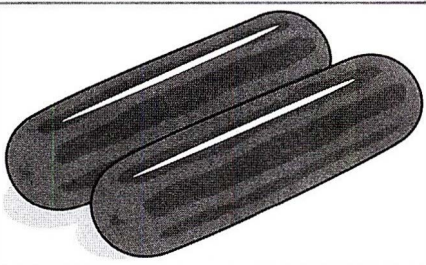

sausages

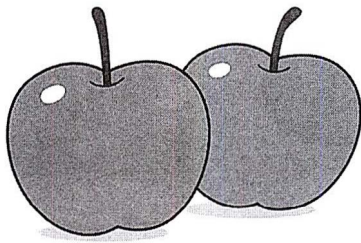

apples



cakes

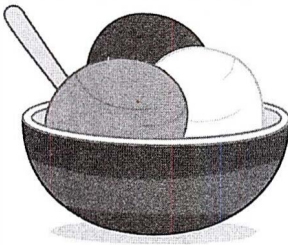

ice cream

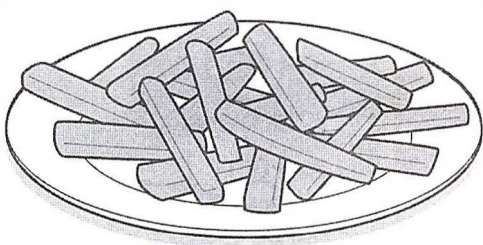

chips

2 Draw faces. 😊 😐 ☹️

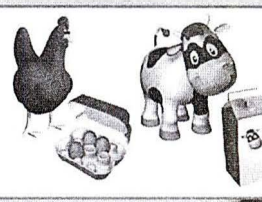
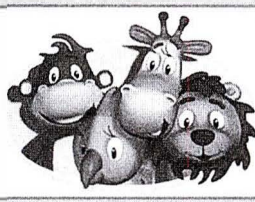
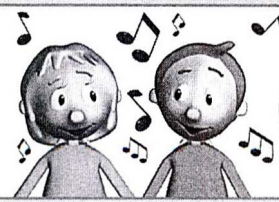

8

All aboard!

1

Think! Match, colour and make sentences.

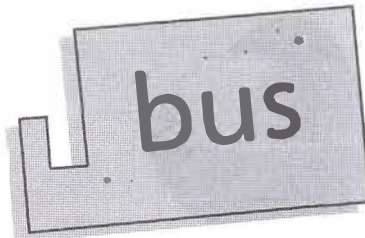
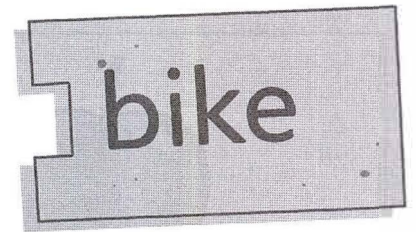
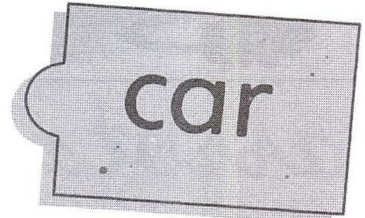
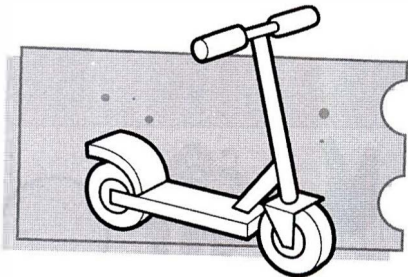
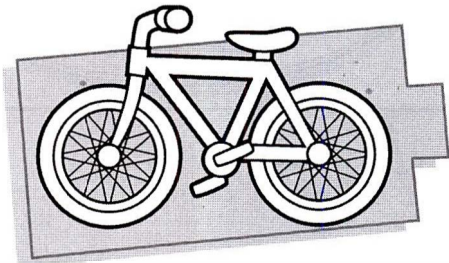
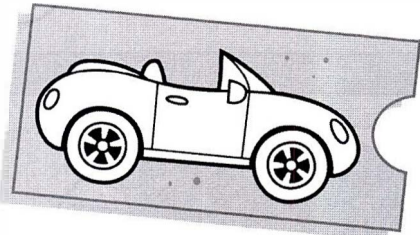
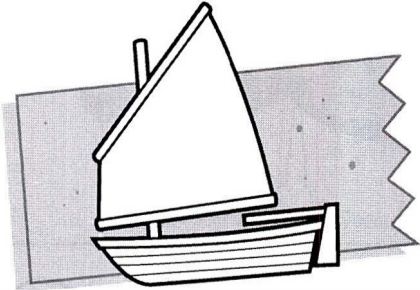
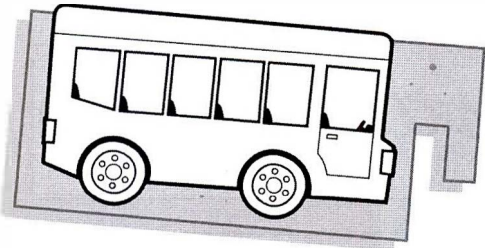

1 Follow the lines. Make sentences.

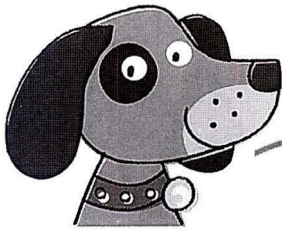
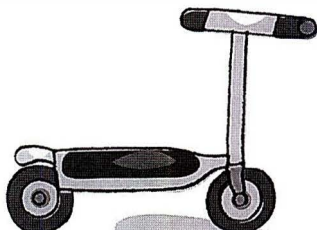
1  

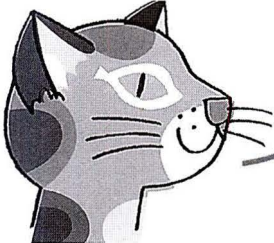
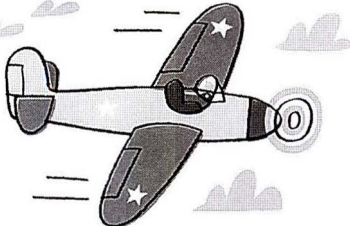
2  

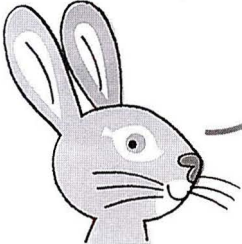
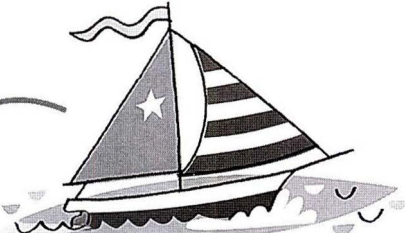
3  

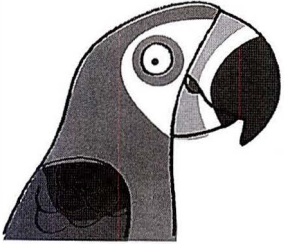
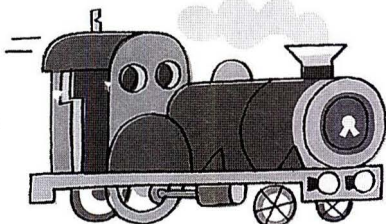
4  

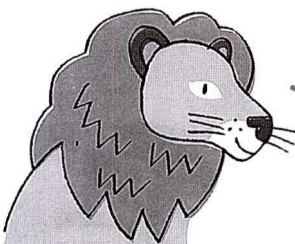
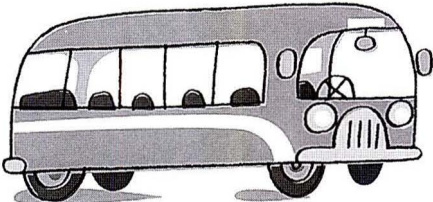
5  

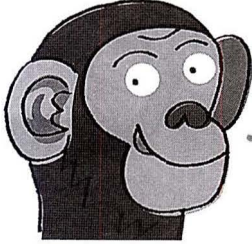
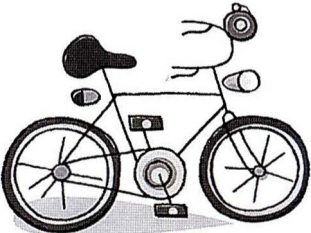
6  

1 CD2
40

Listen, point and say the words.

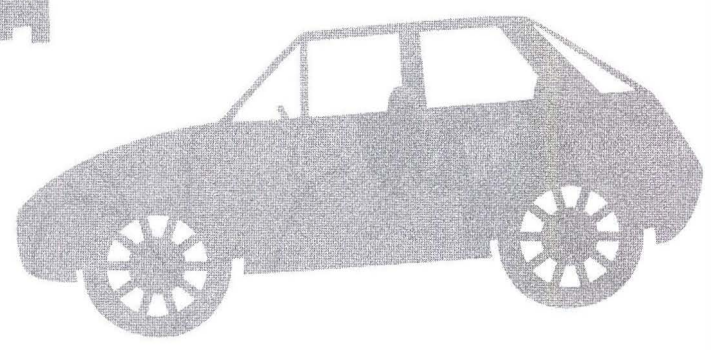
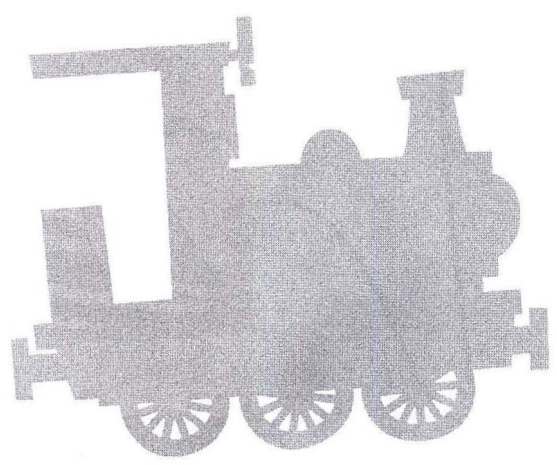
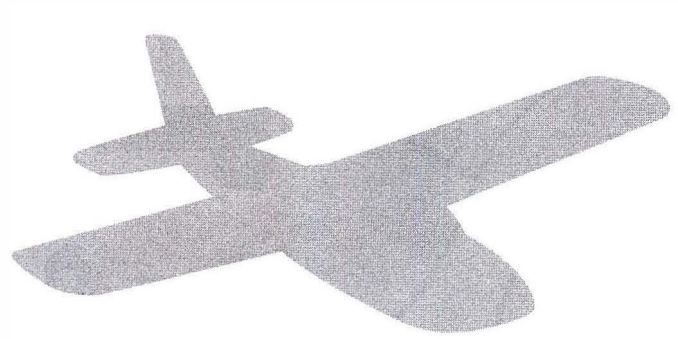

1 CD2
42

Think! Listen and circle.

1

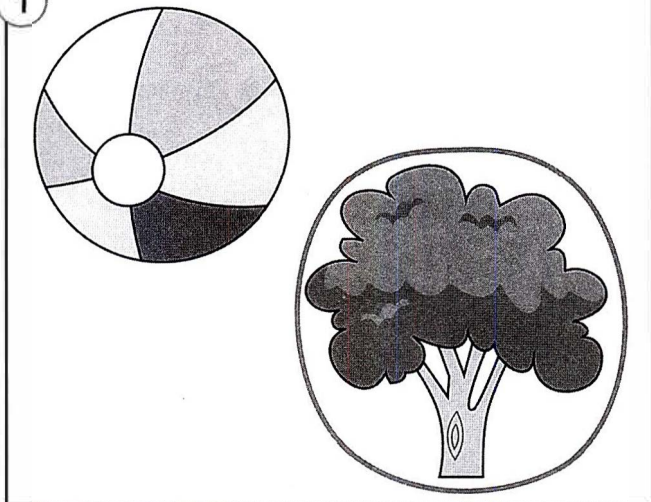

2

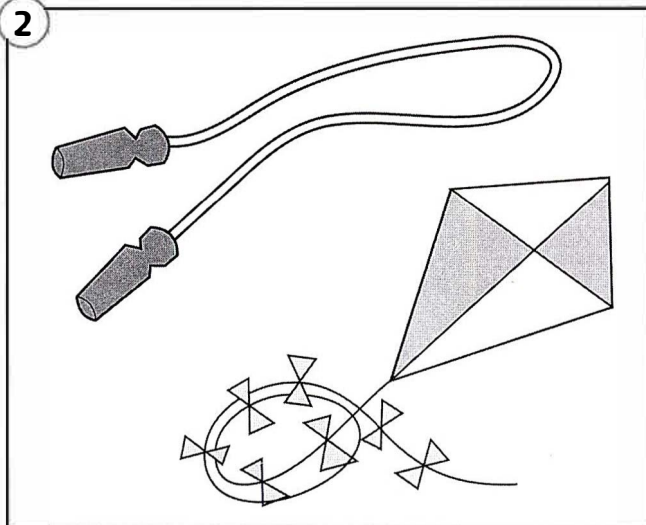

3

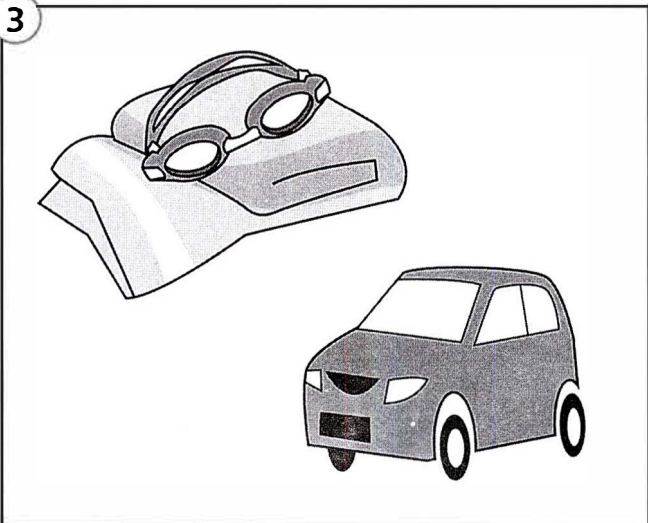

4

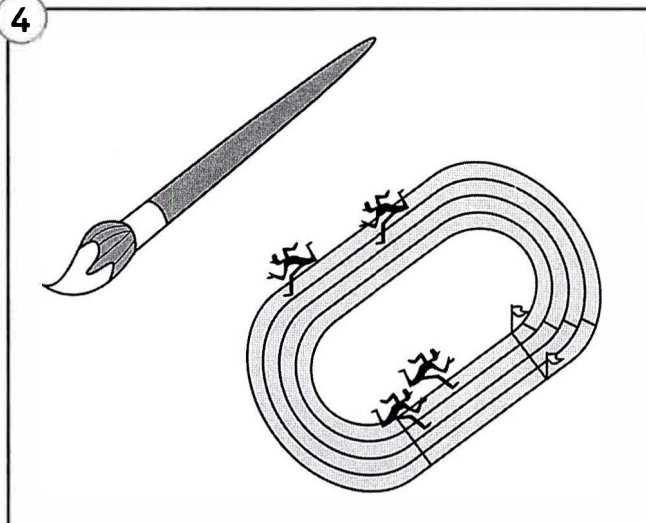

5

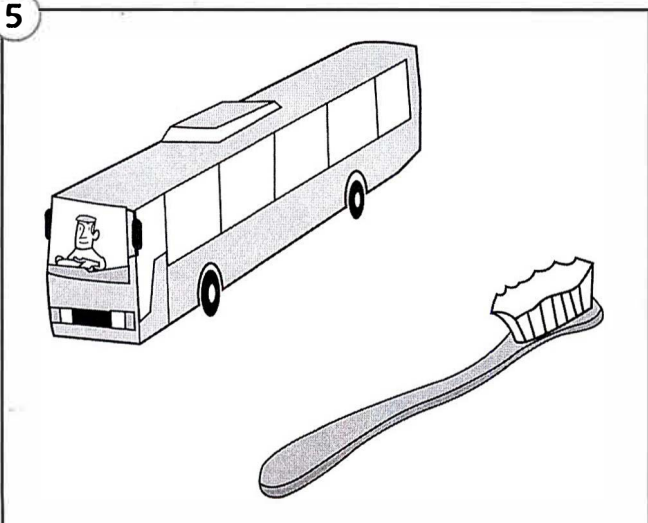

6

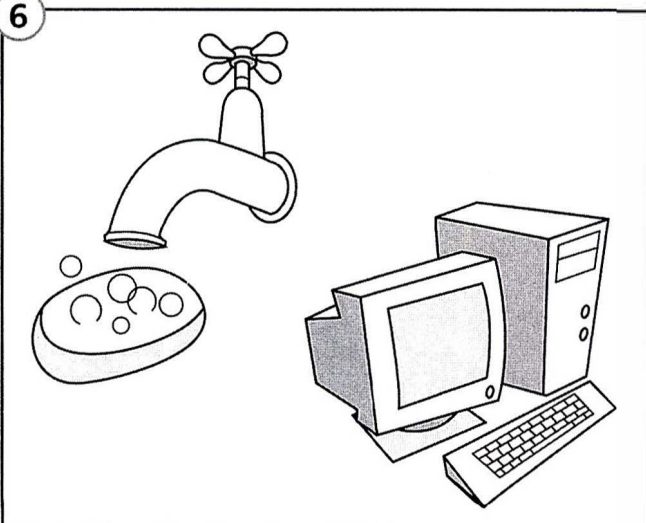

flying a kite, swimming, climbing a tree, running,
brushing my teeth, washing my hands

Listen and trace.

1

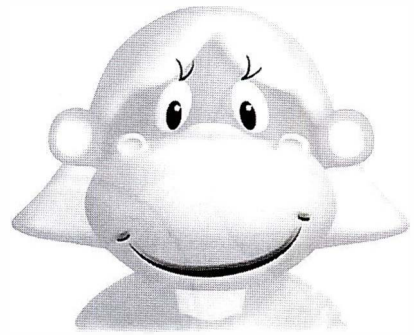
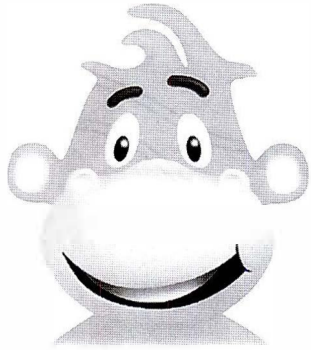

2

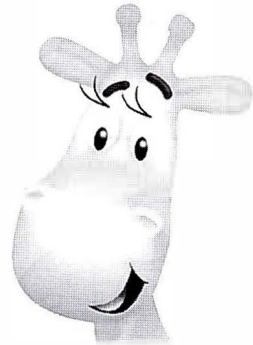

3



4

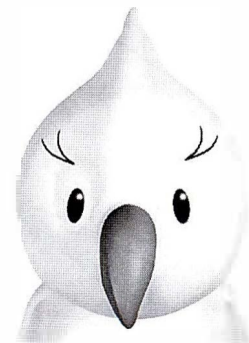

1 Think! Look and colour.

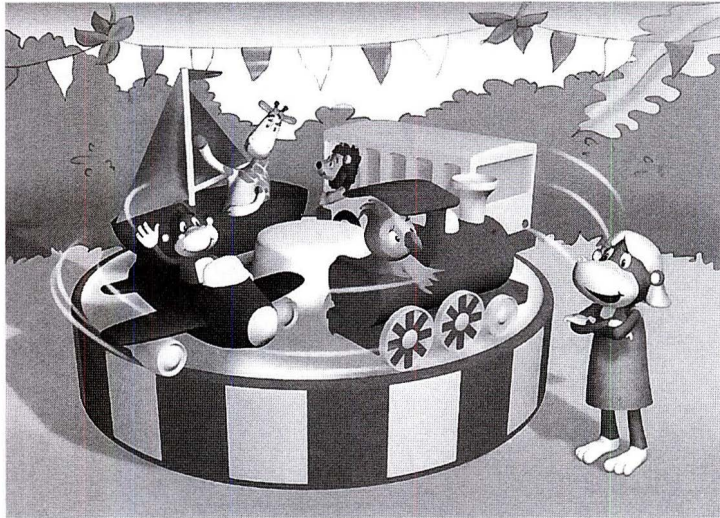

1 Trace with four colours to match.



2 Draw and say the shapes. □ △ ▭ ○

1

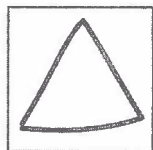

2

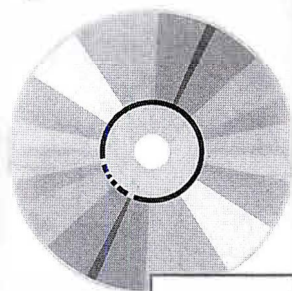

3

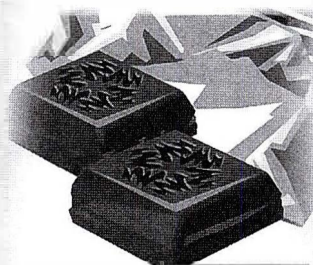

4

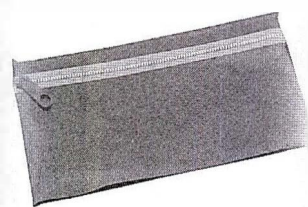

5

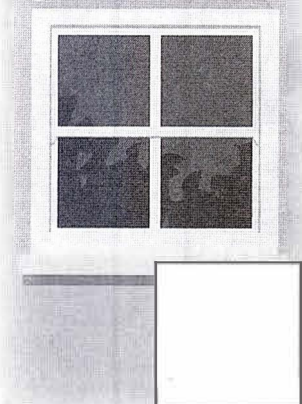

6

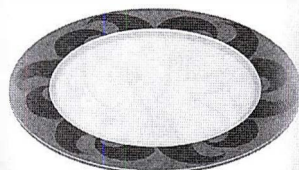

7

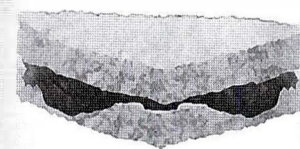



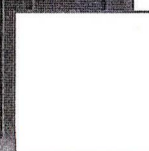
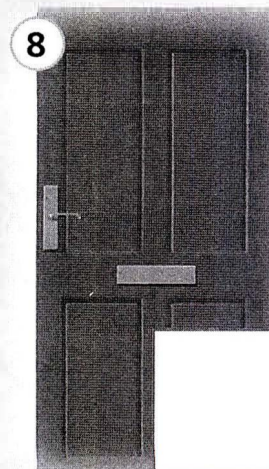

8

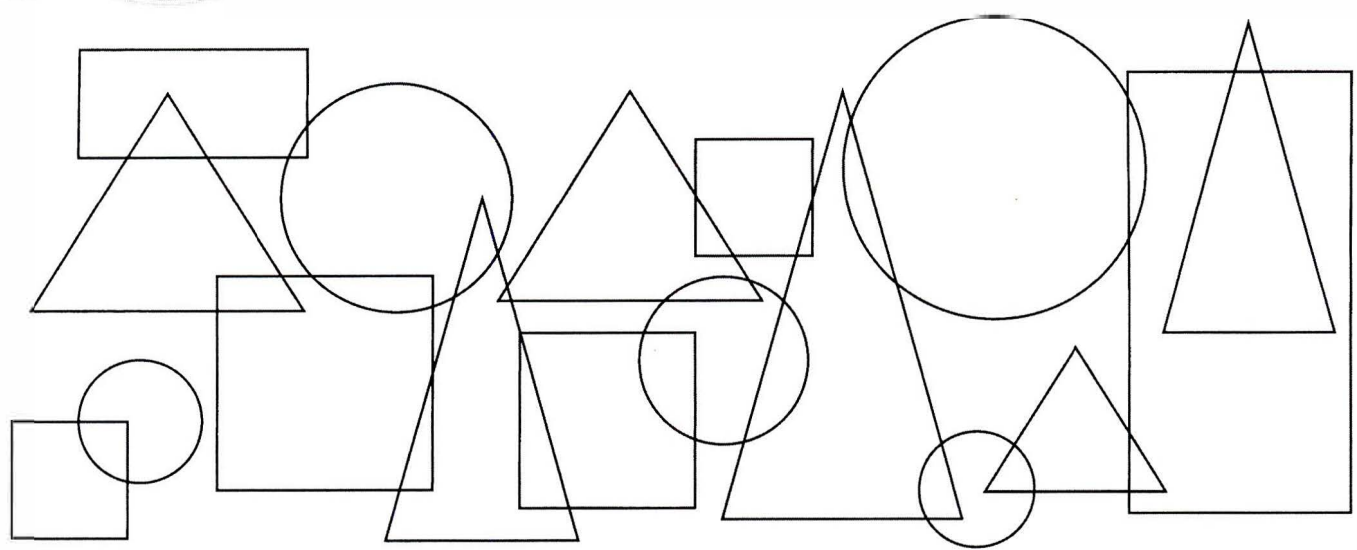

1 Think! Count and circle.



	1	2	3	4	5	6
	1	2	3	4	5	6
	1	2	3	4	5	6
	1	2	3	4	5	6

2 CD2
46 Listen and colour.

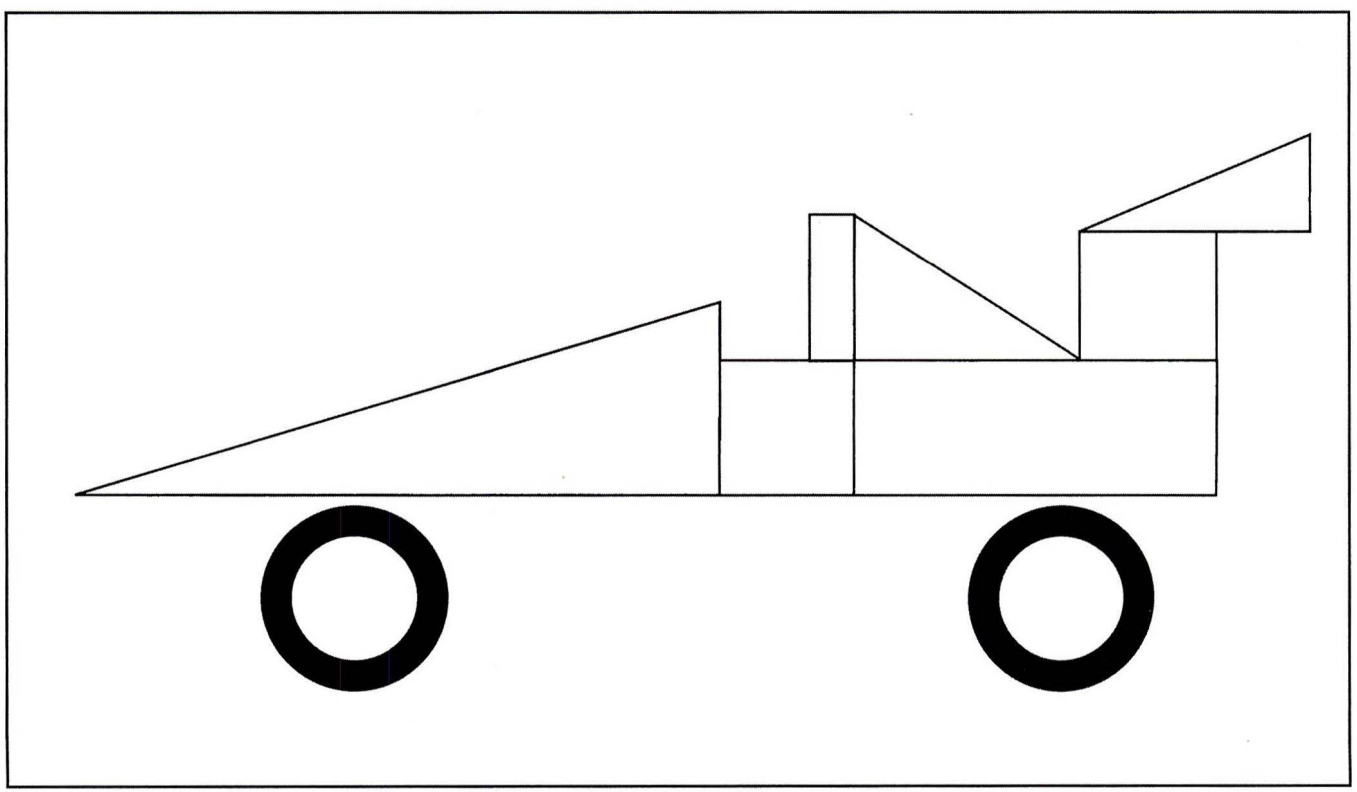

1

Have a boat race.

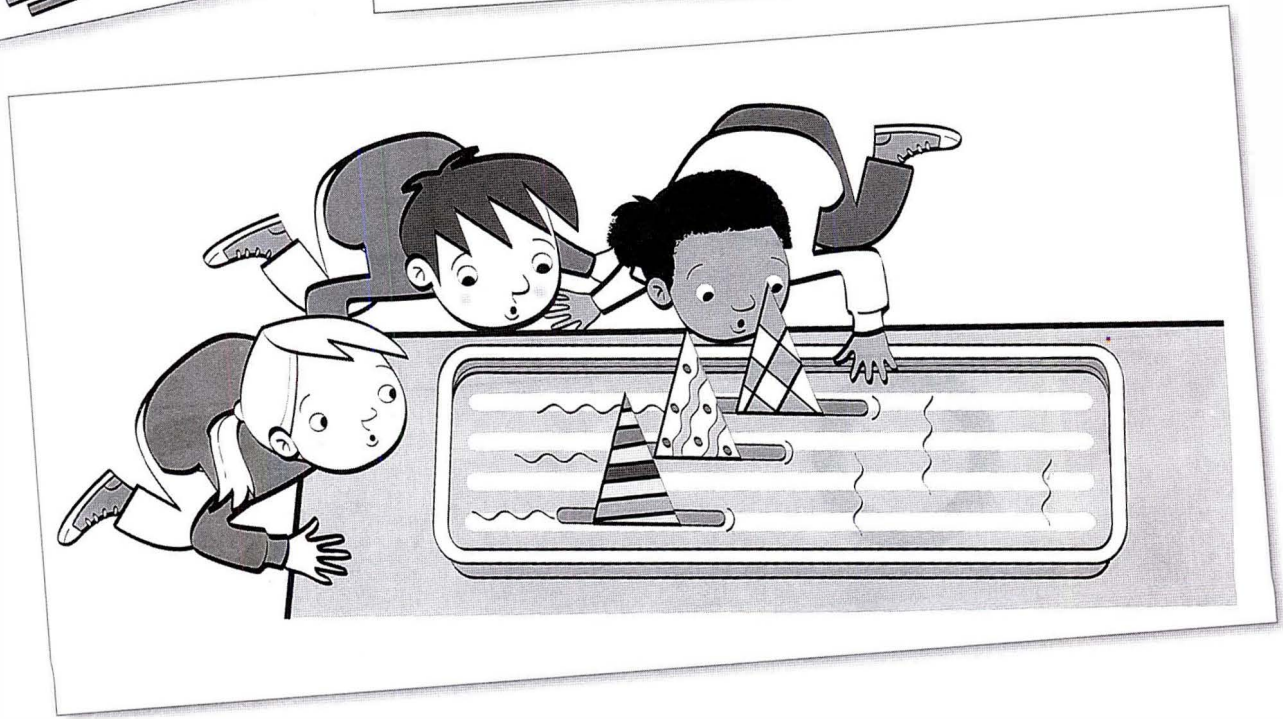
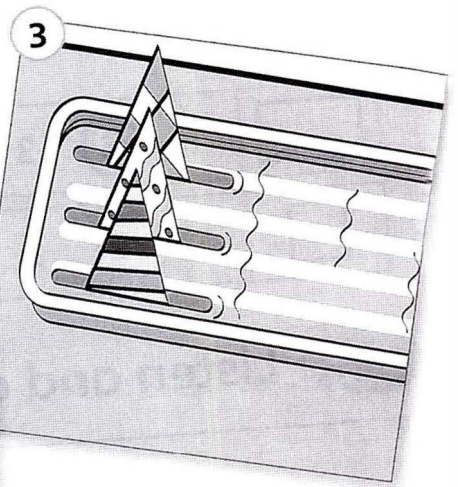
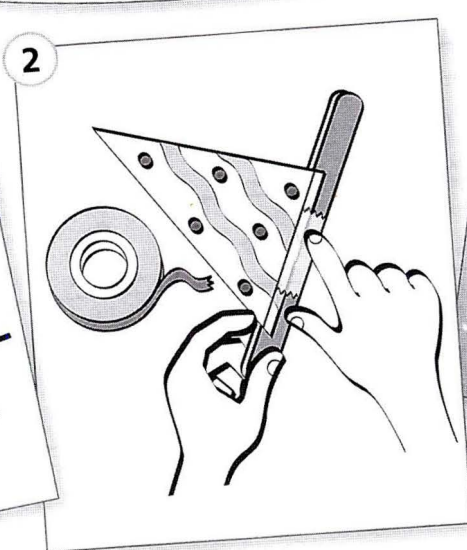
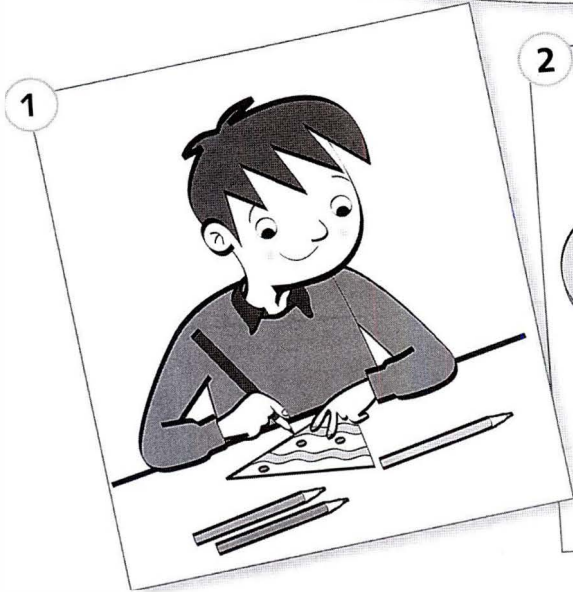
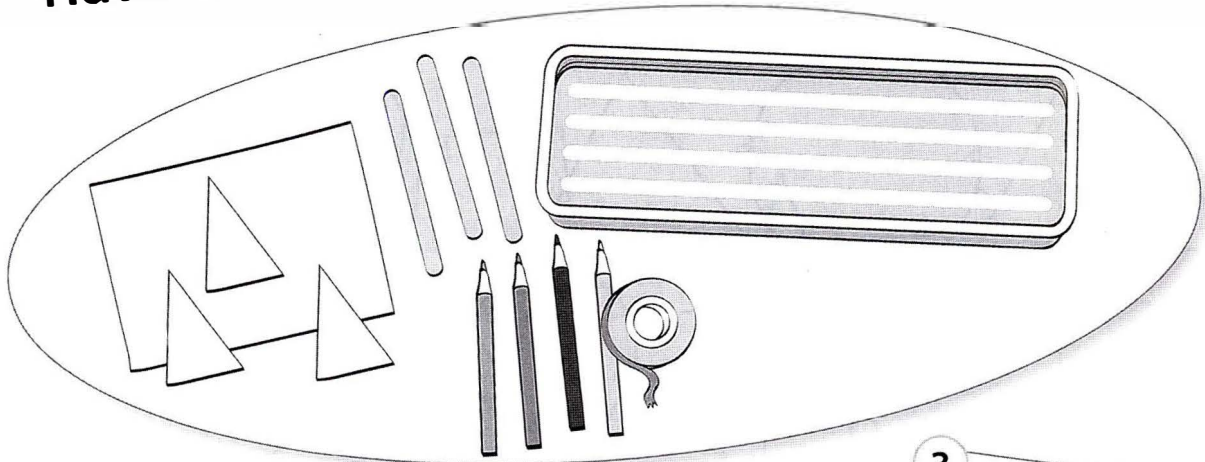

1 Say the words and trace. Colour the circles.

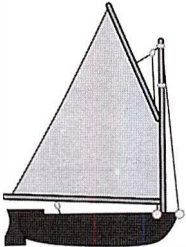

boat

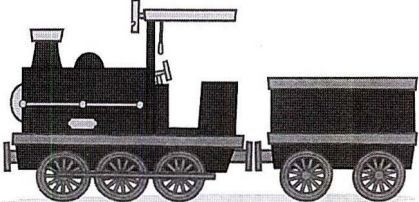

train

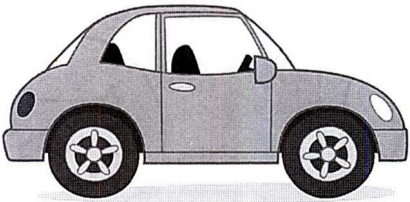

car

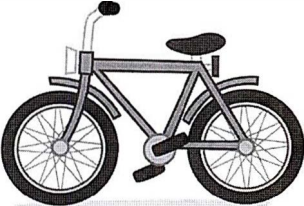

bike

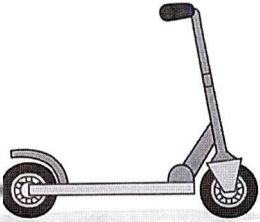

scooter

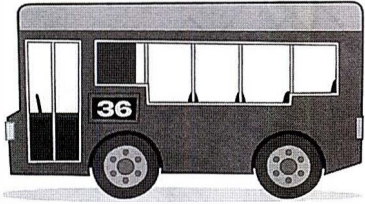

bus

2 Draw faces. 😊 😐 😞

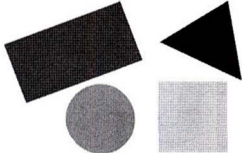
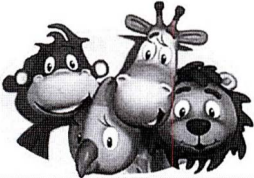

9

Party clothes

1 Colour and describe.

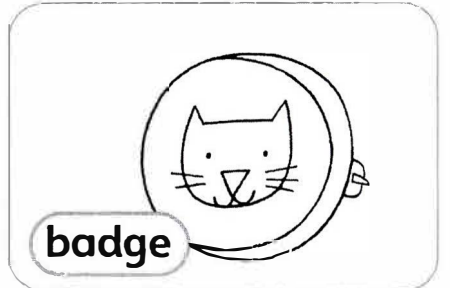
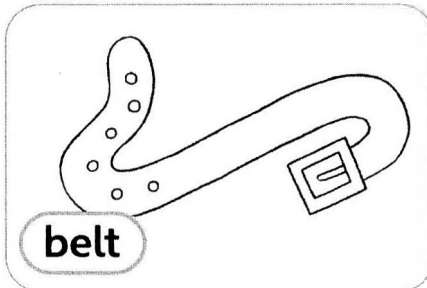
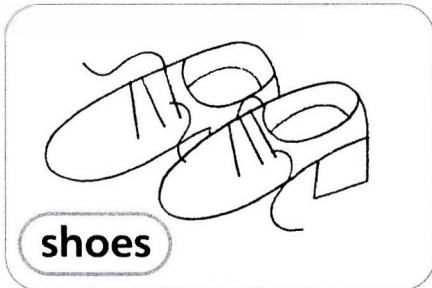
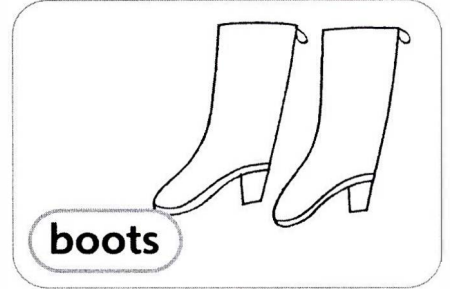
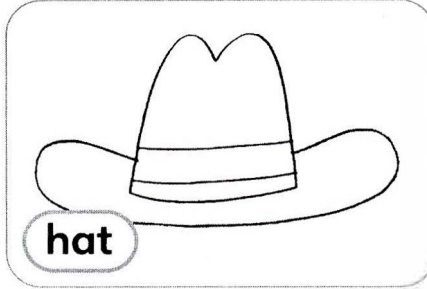
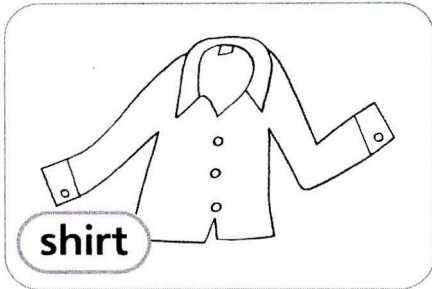

2 Draw five lines. Guess with your friend.

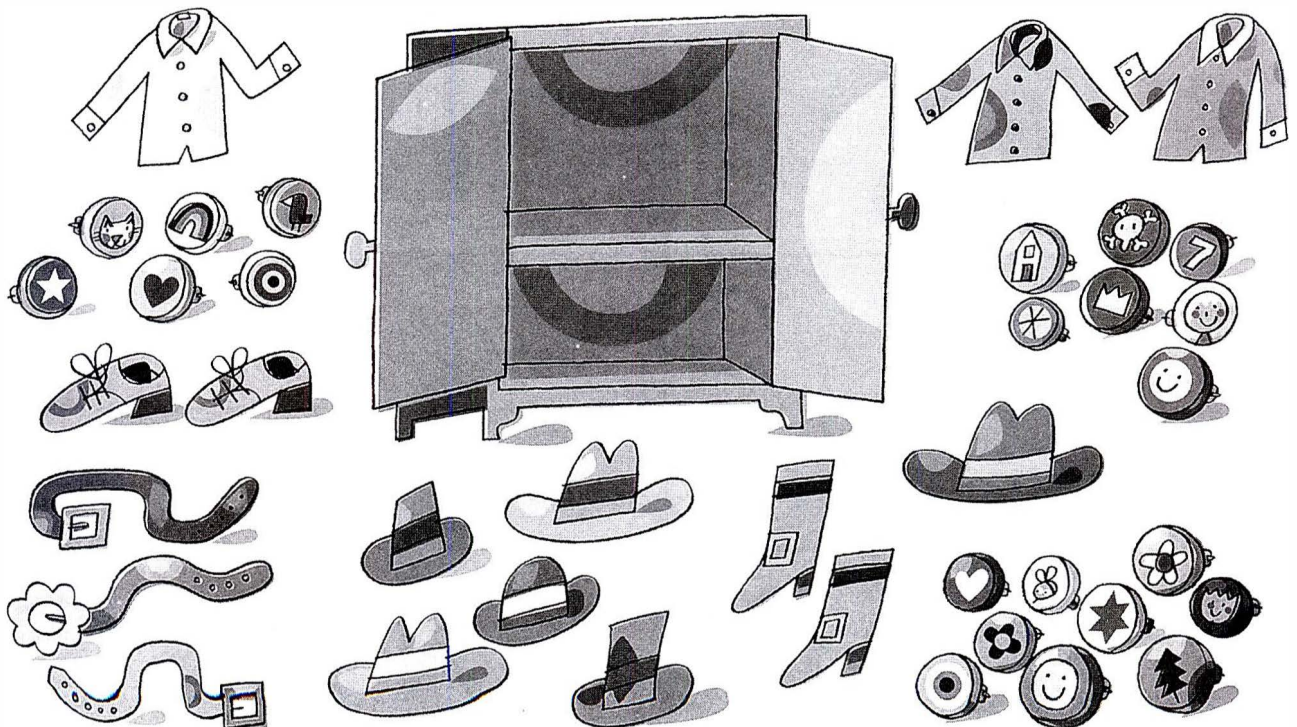

1 Think! Follow the food and drink.



I like (biscuits, crisps, salad, sweets).

1

Find five differences.

1

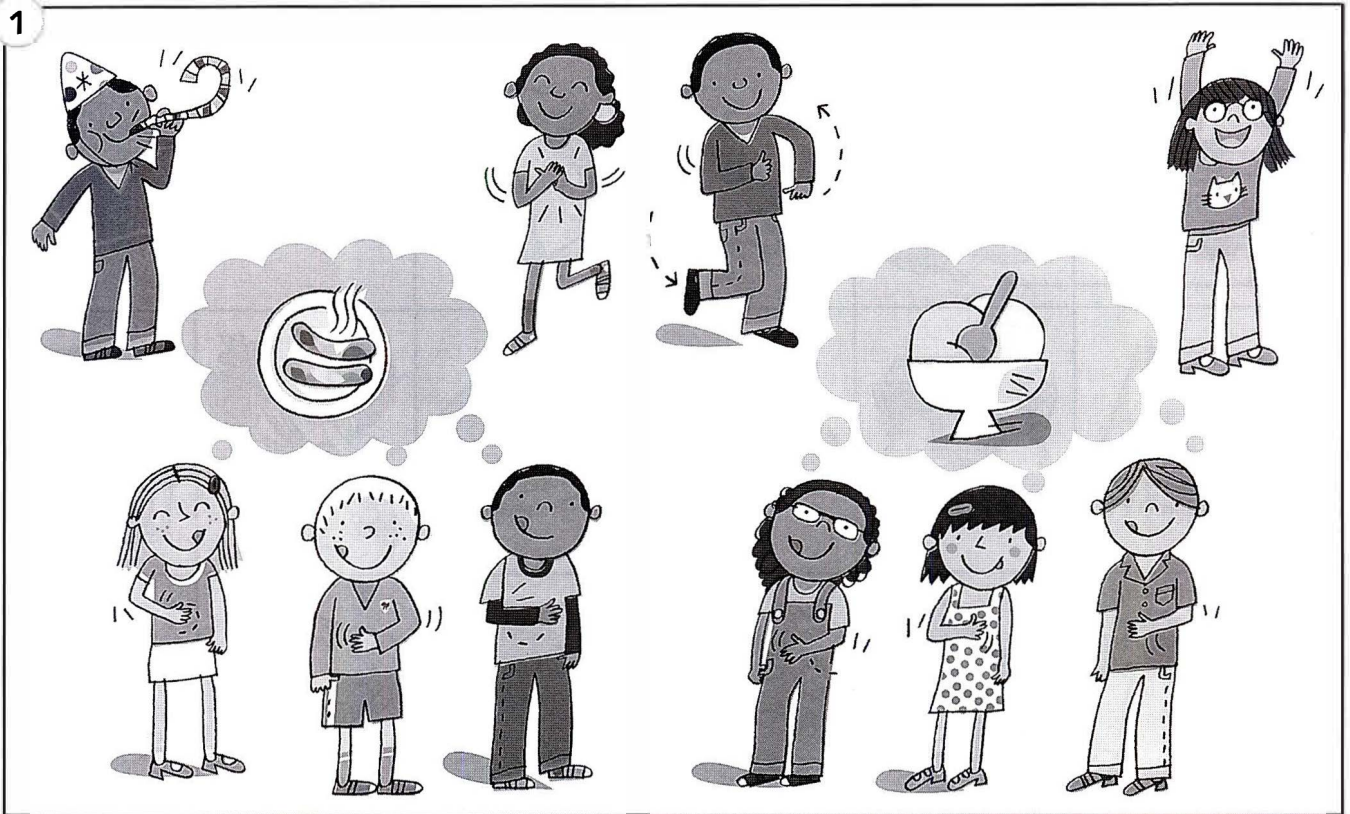

2

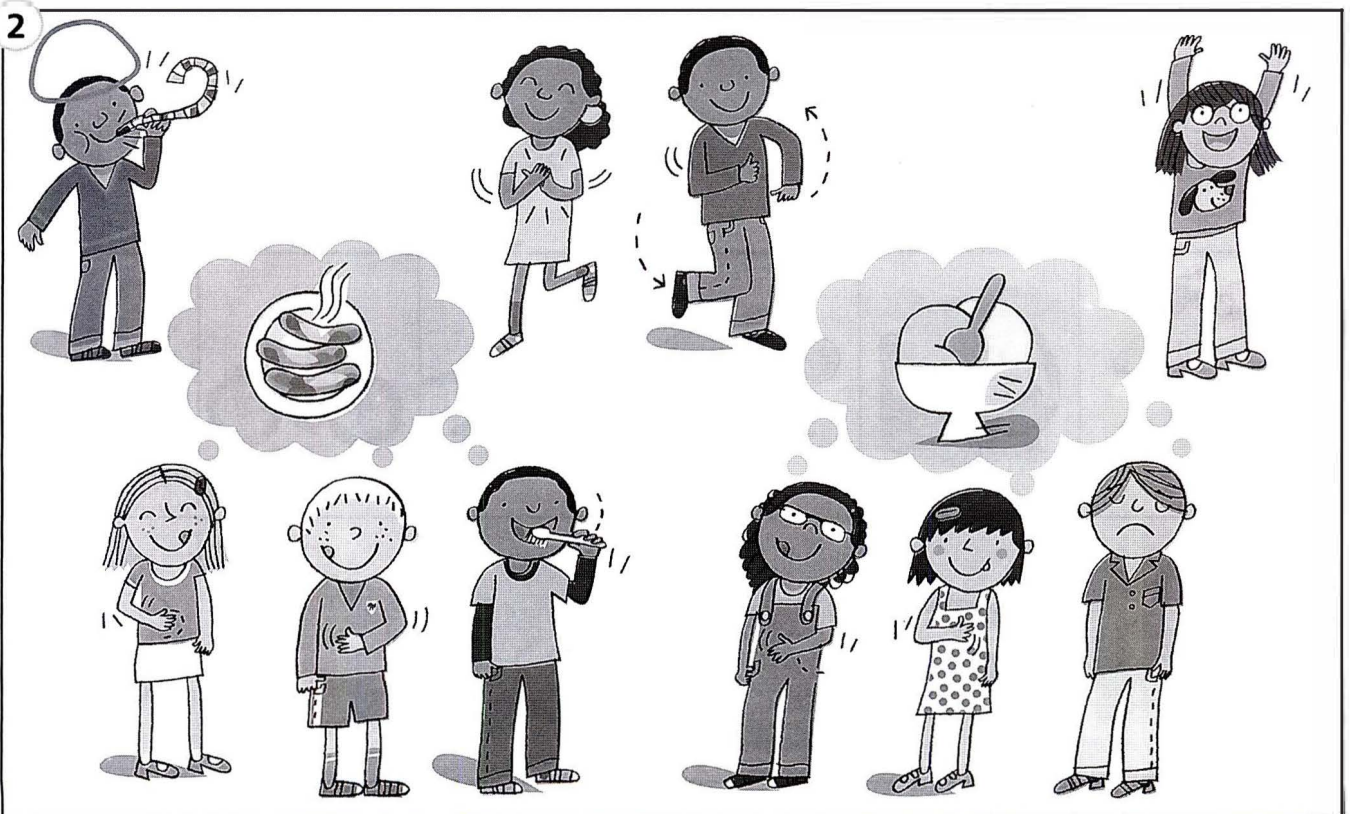

1 Think! Look and cross out.

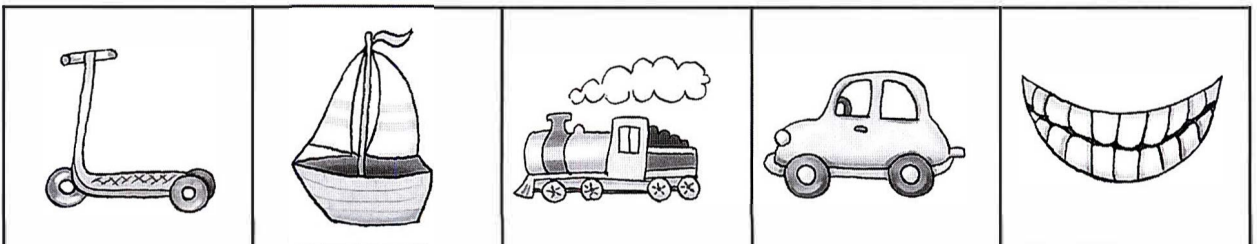
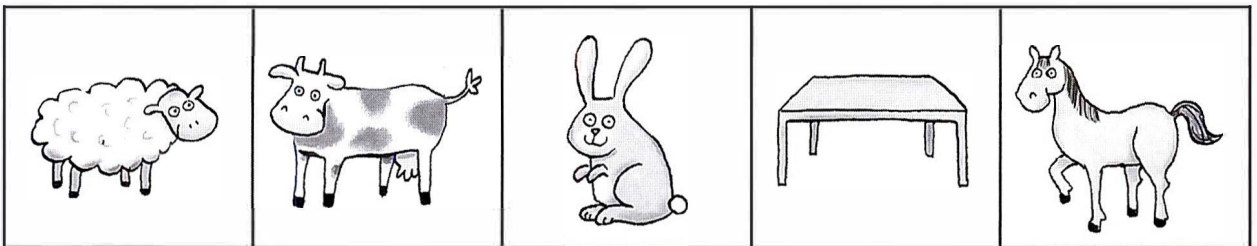
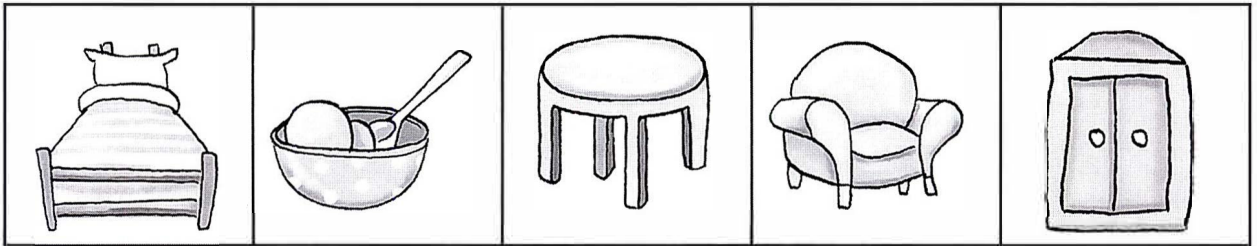
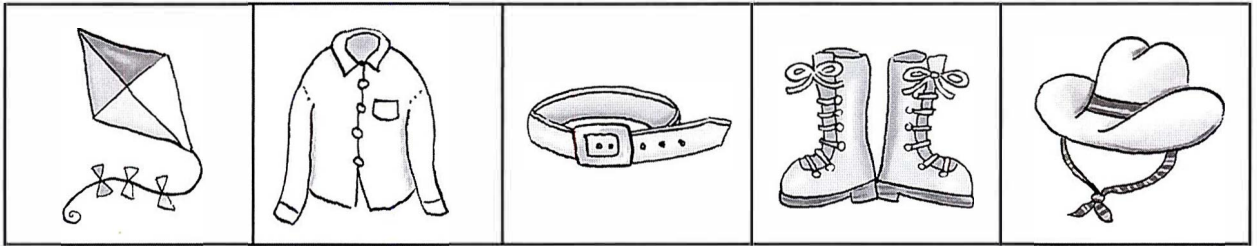
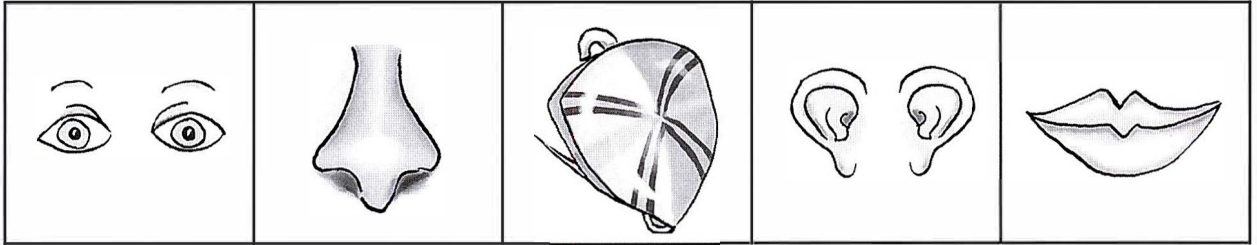
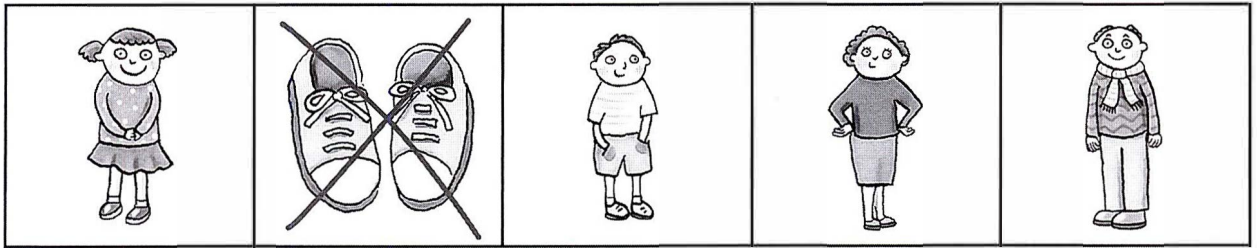

Listen and trace.

1

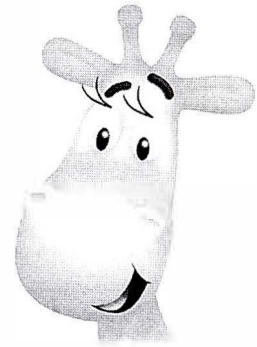
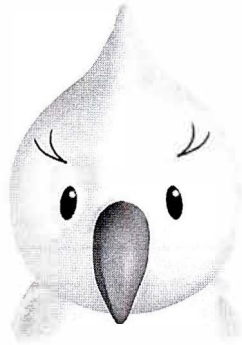

2

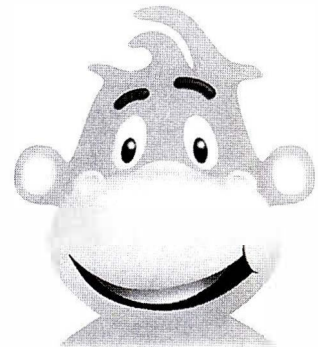

3

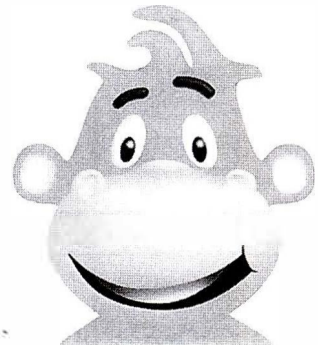
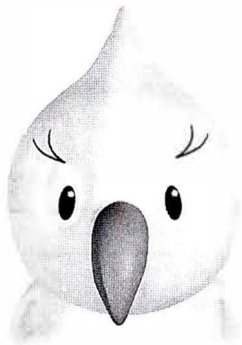

4

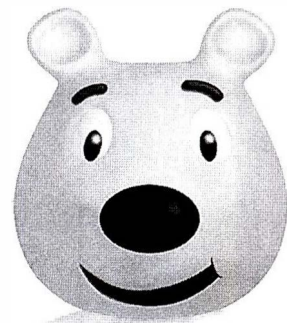
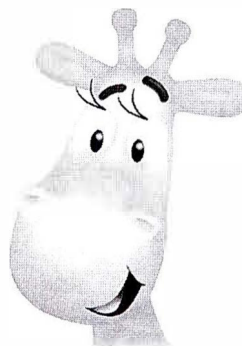

1 Think! Look and colour.

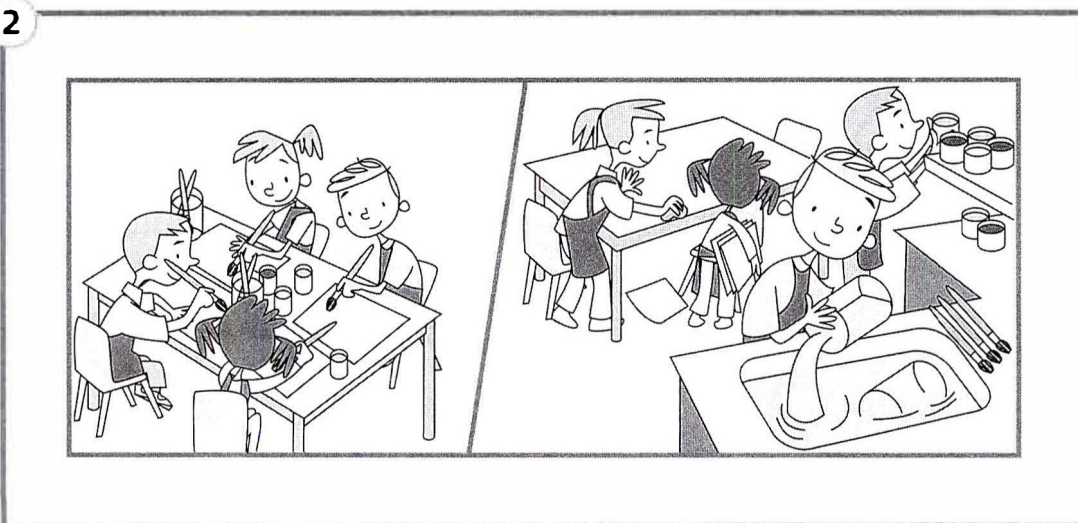
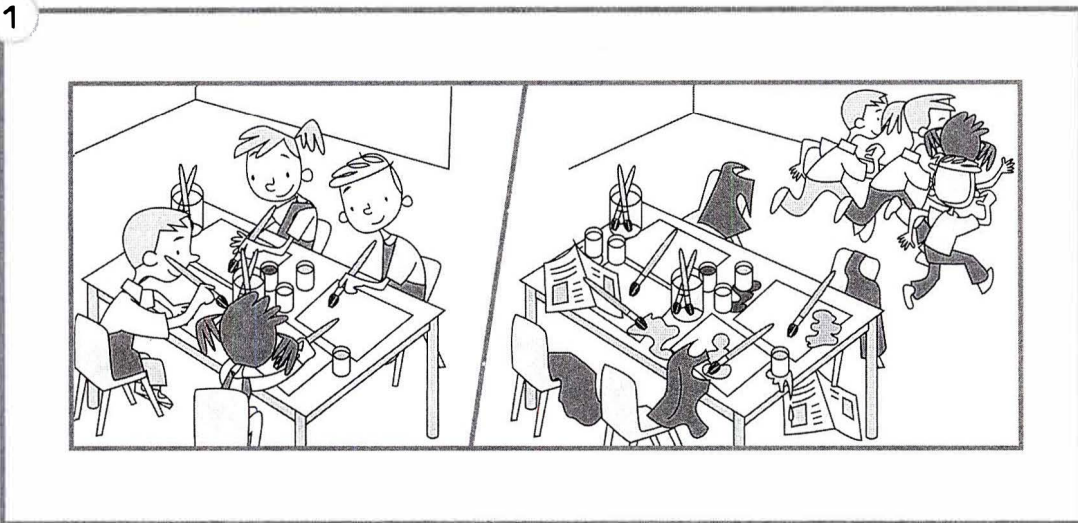
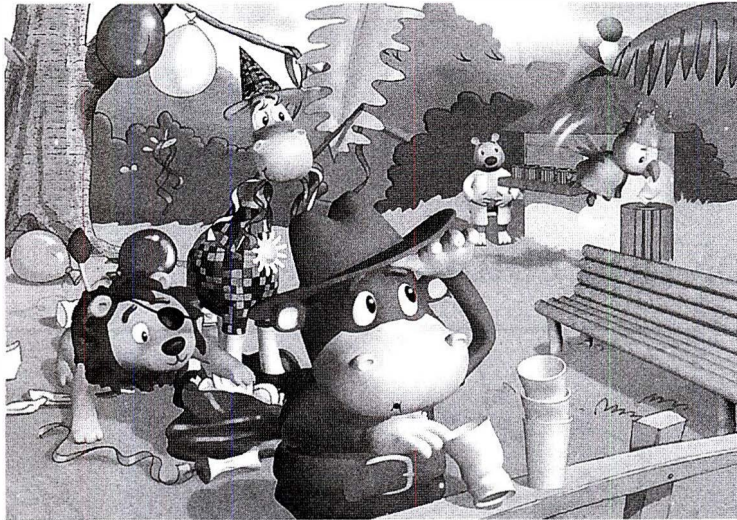

1 CD2
58 Listen and colour.

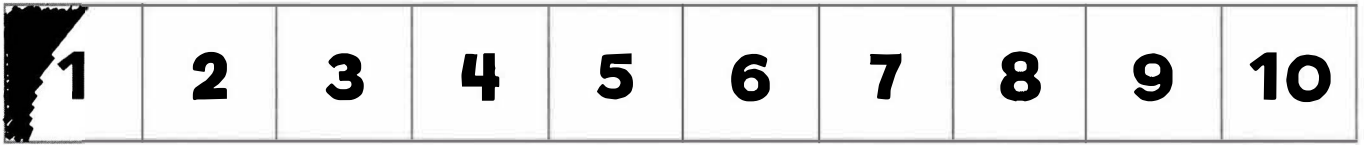

2 Think! Look and colour.



1 Colour. Follow the lines. Describe the uniforms.



1 Make a pirate hat.

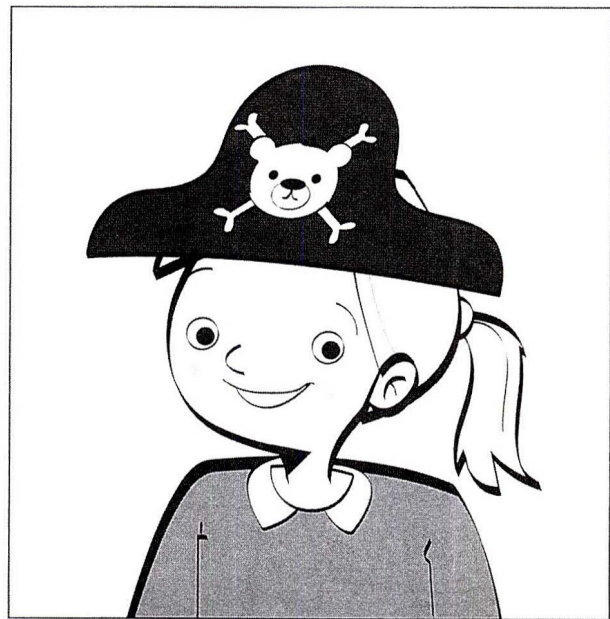
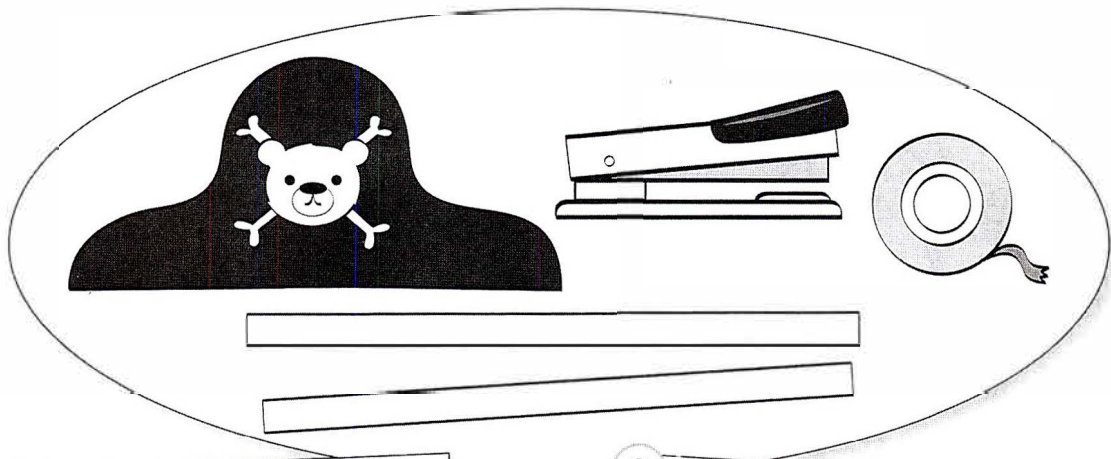

1 Say the words and trace. Colour the circles.



shirt

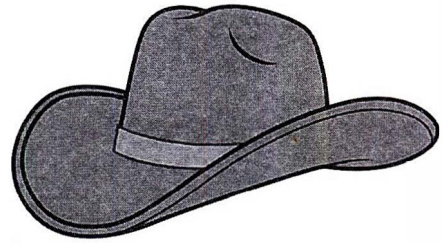

hat



boots



shoes

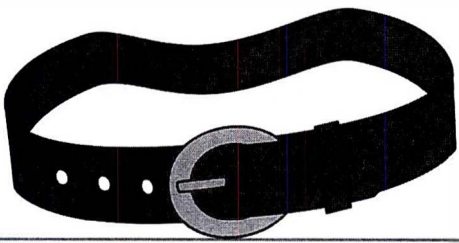

belt

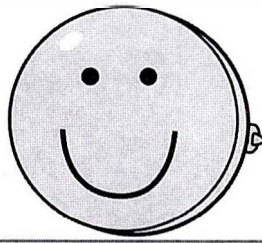

badge

2 Draw faces. 😊 😐 😞

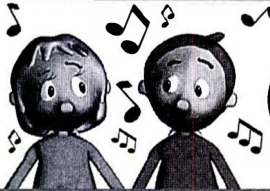

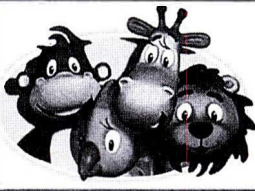

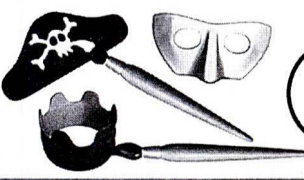







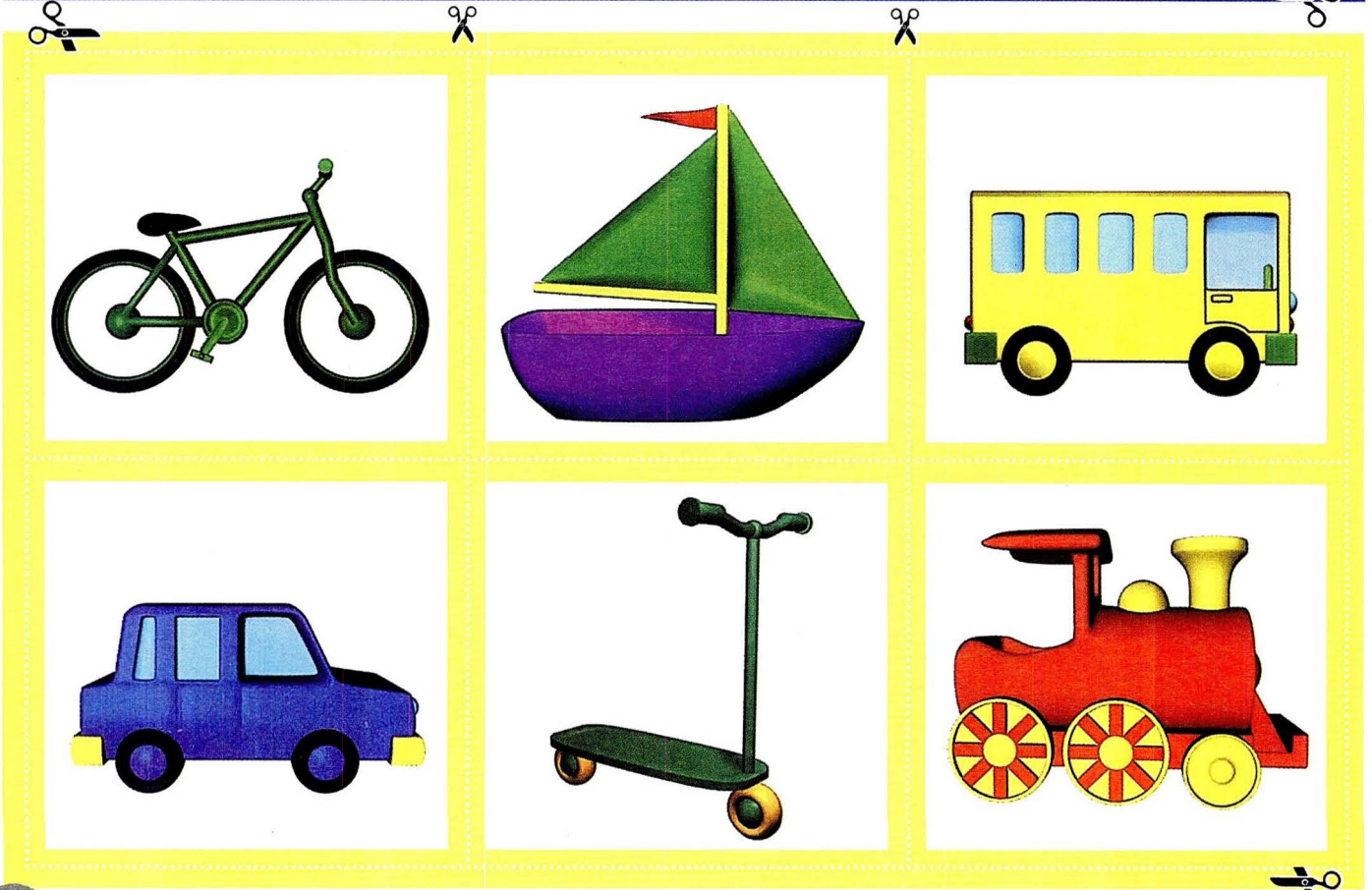
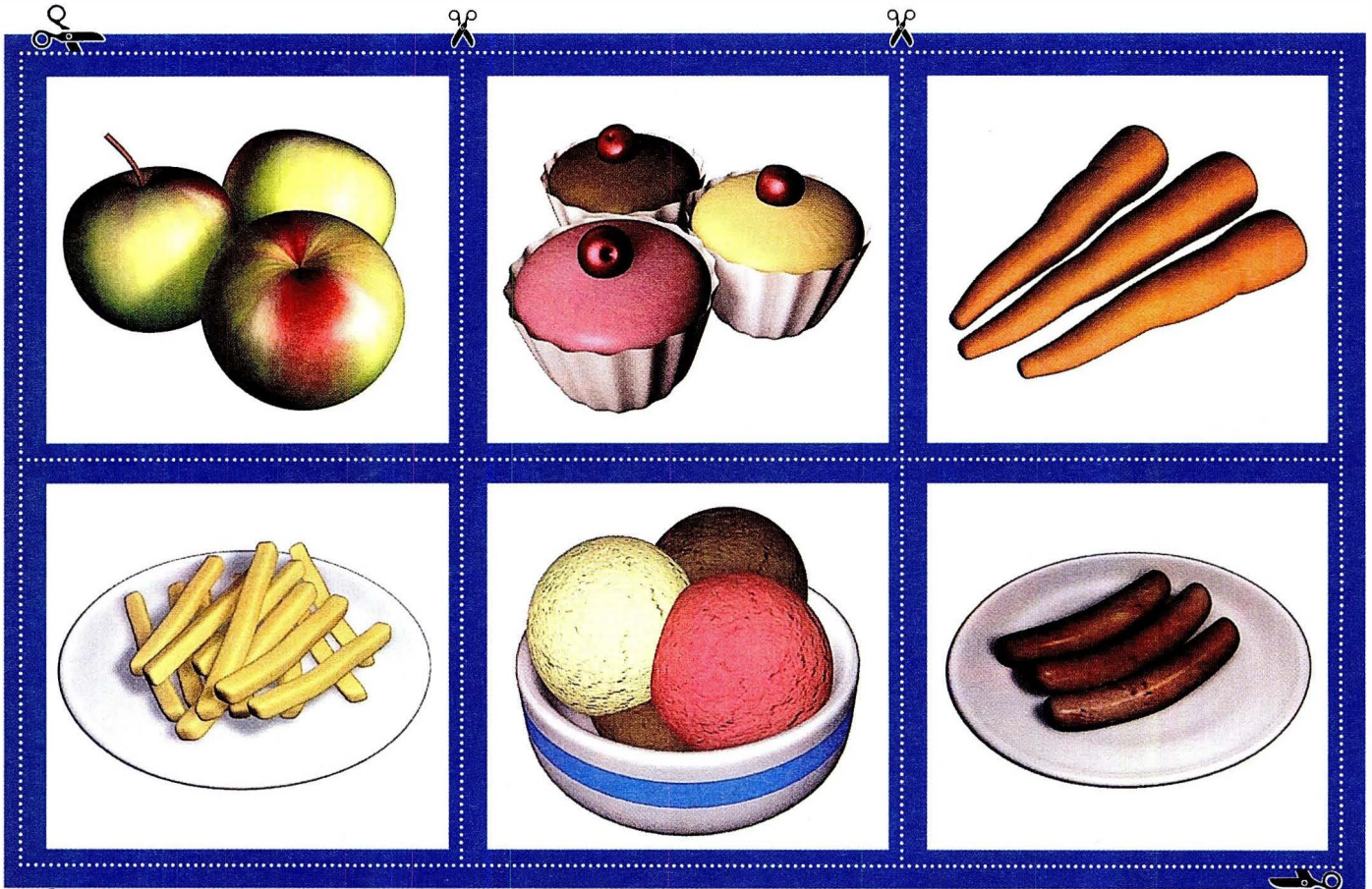

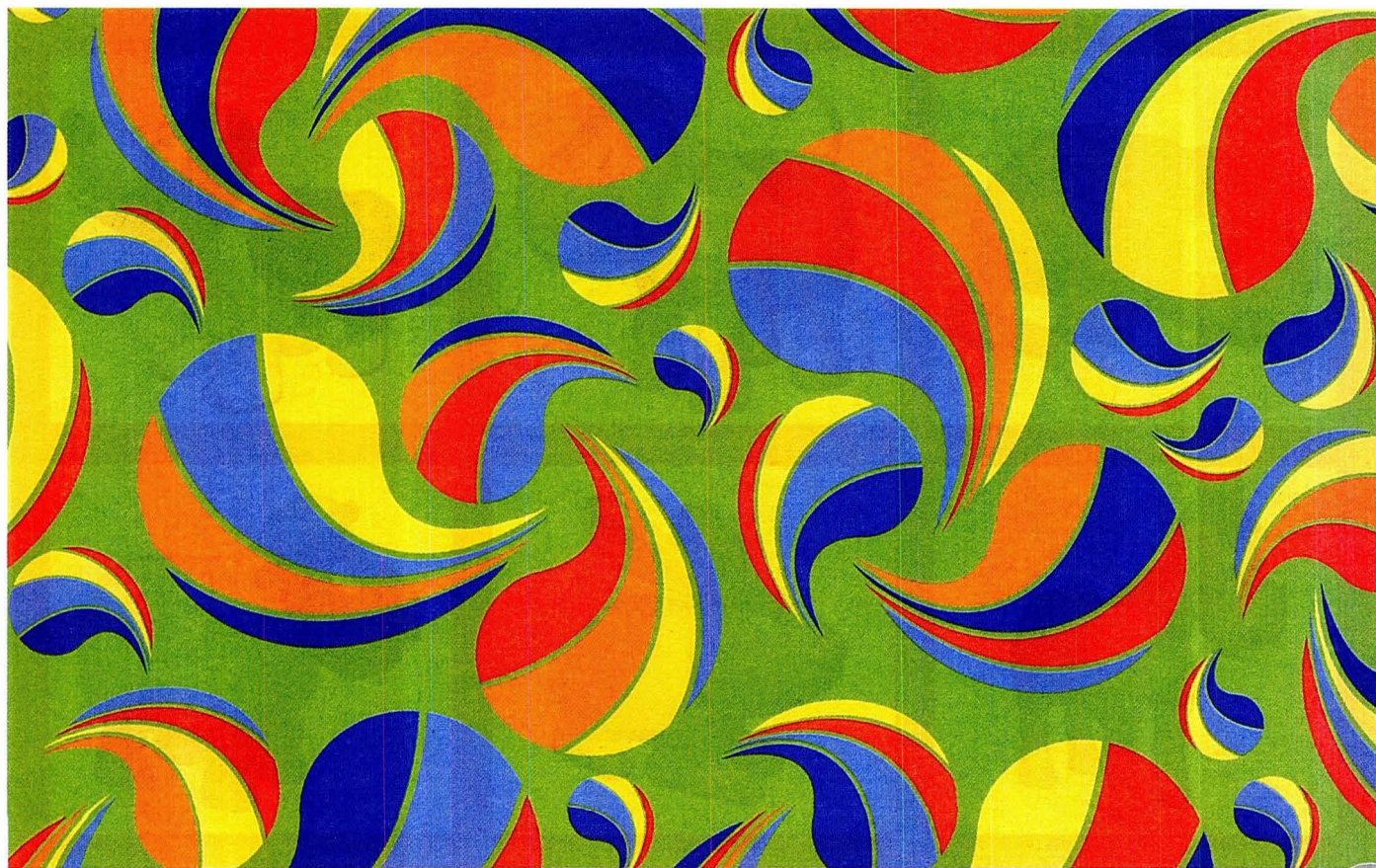

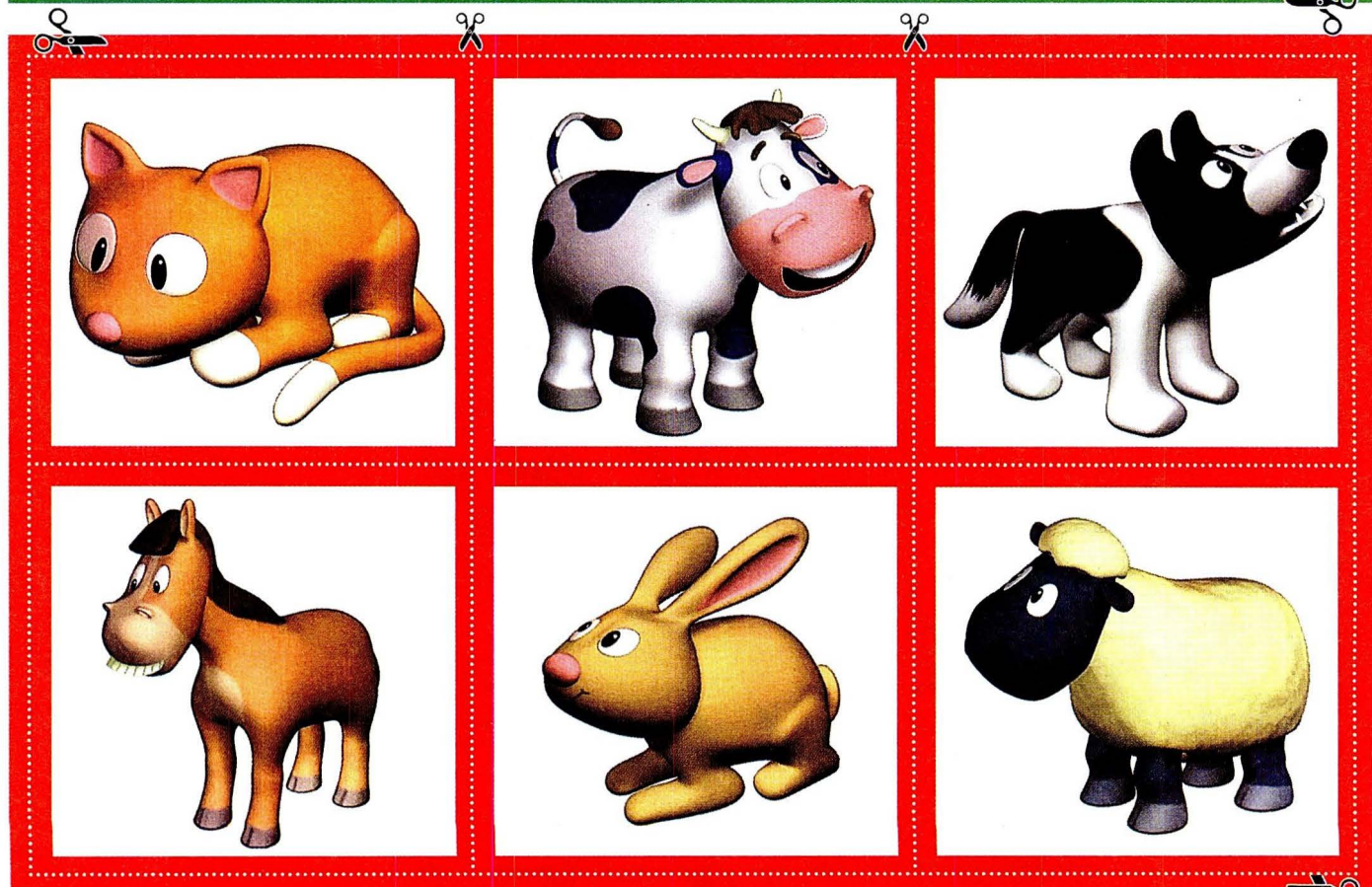



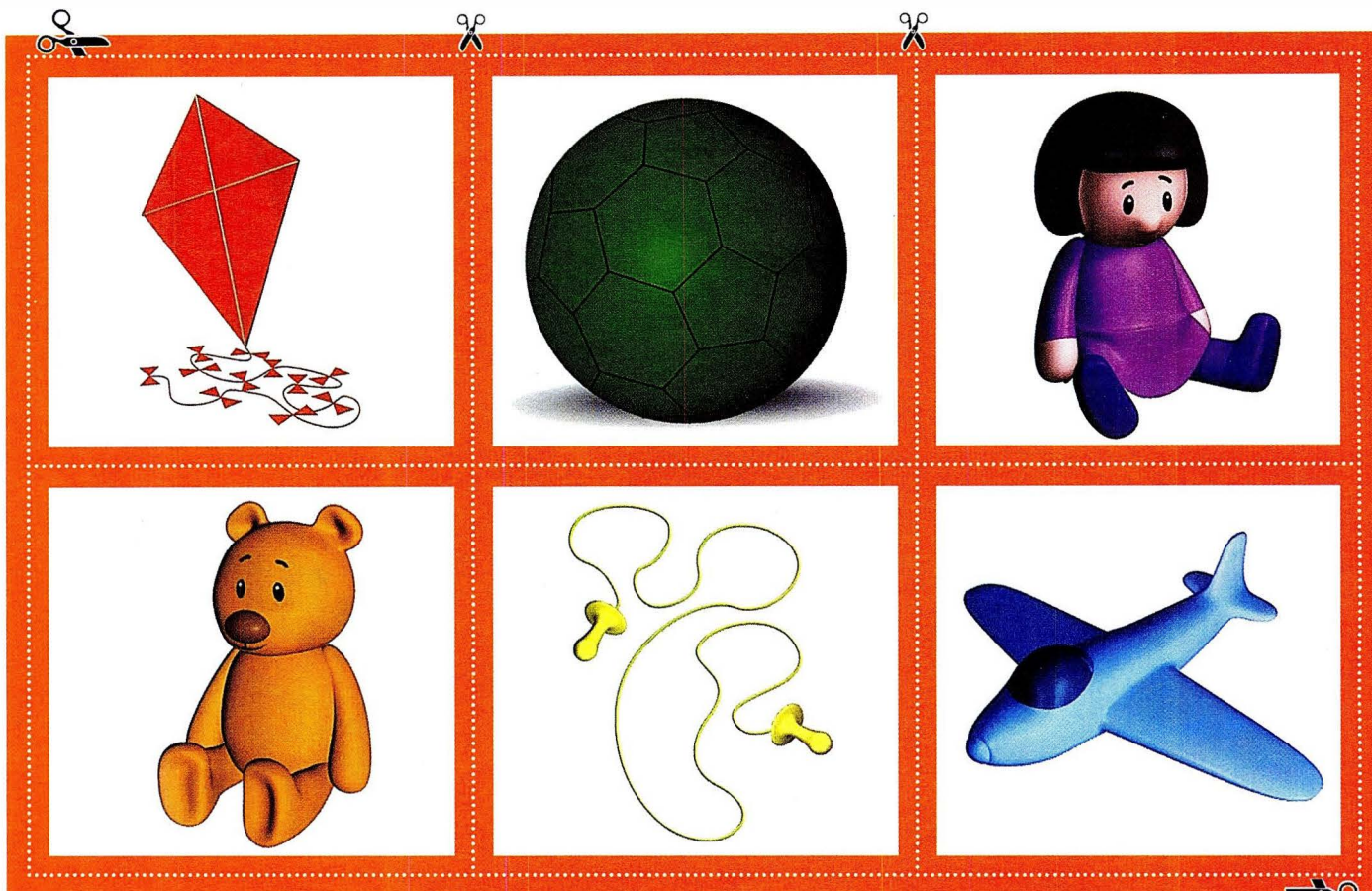



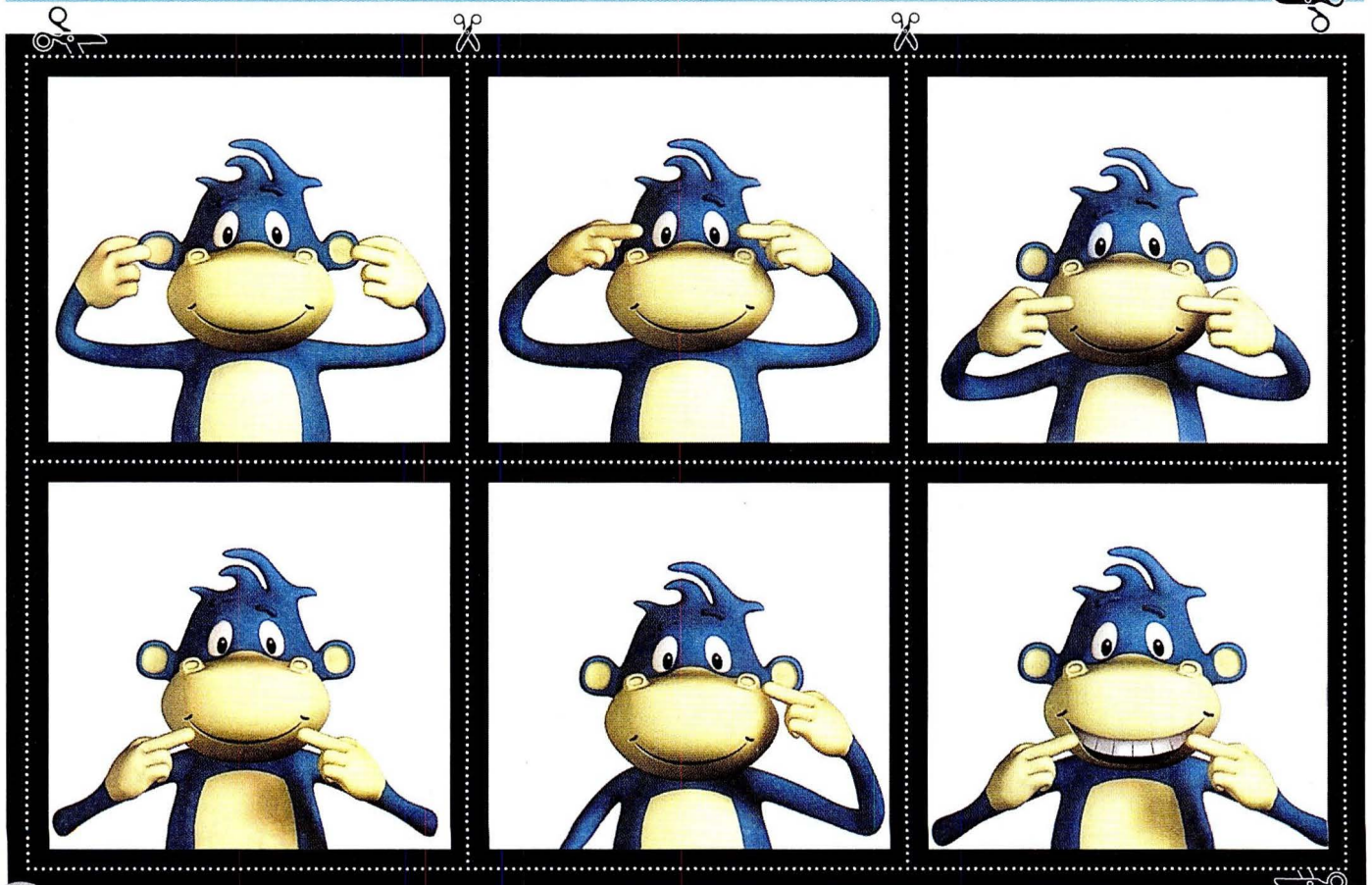
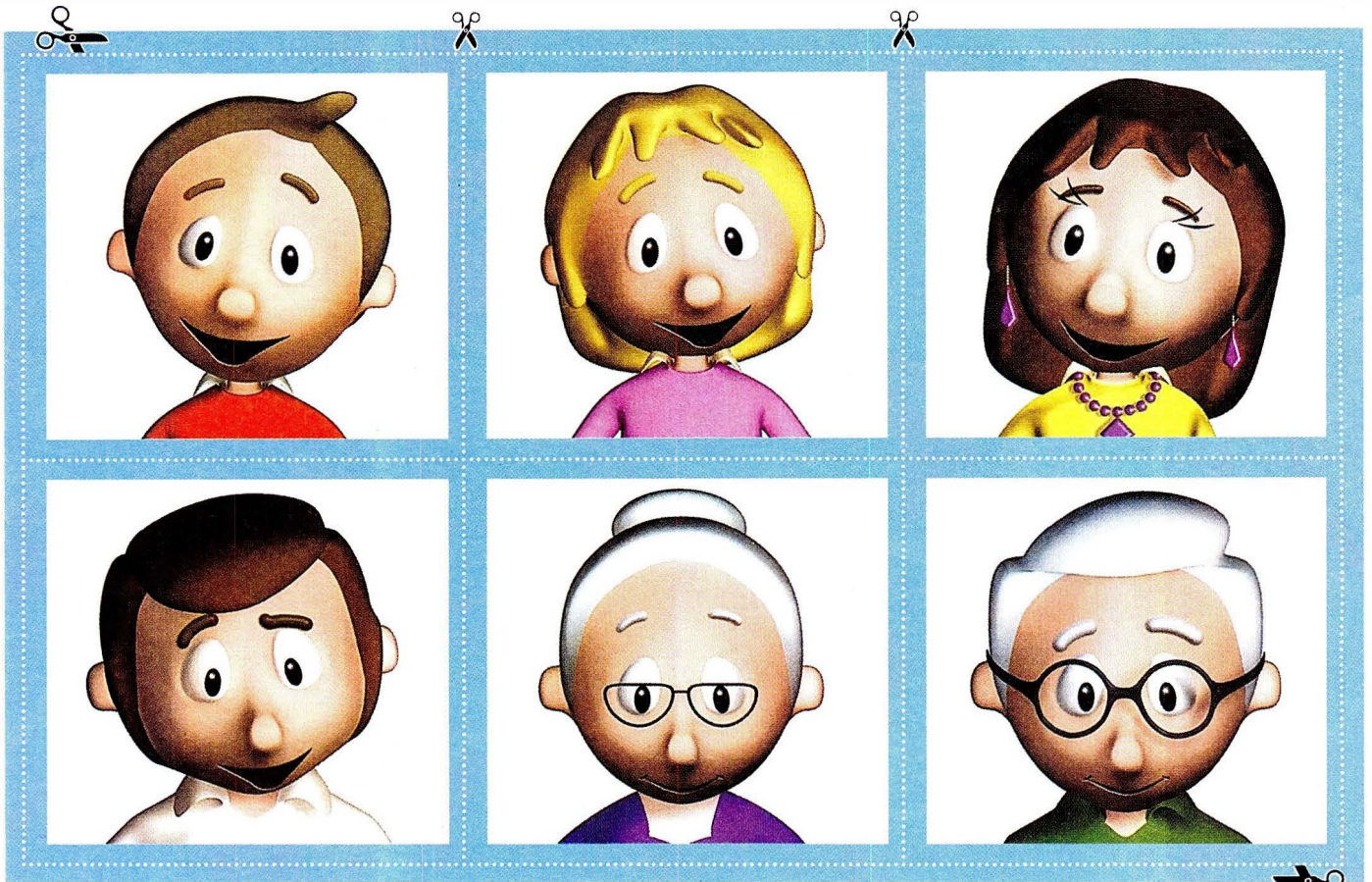





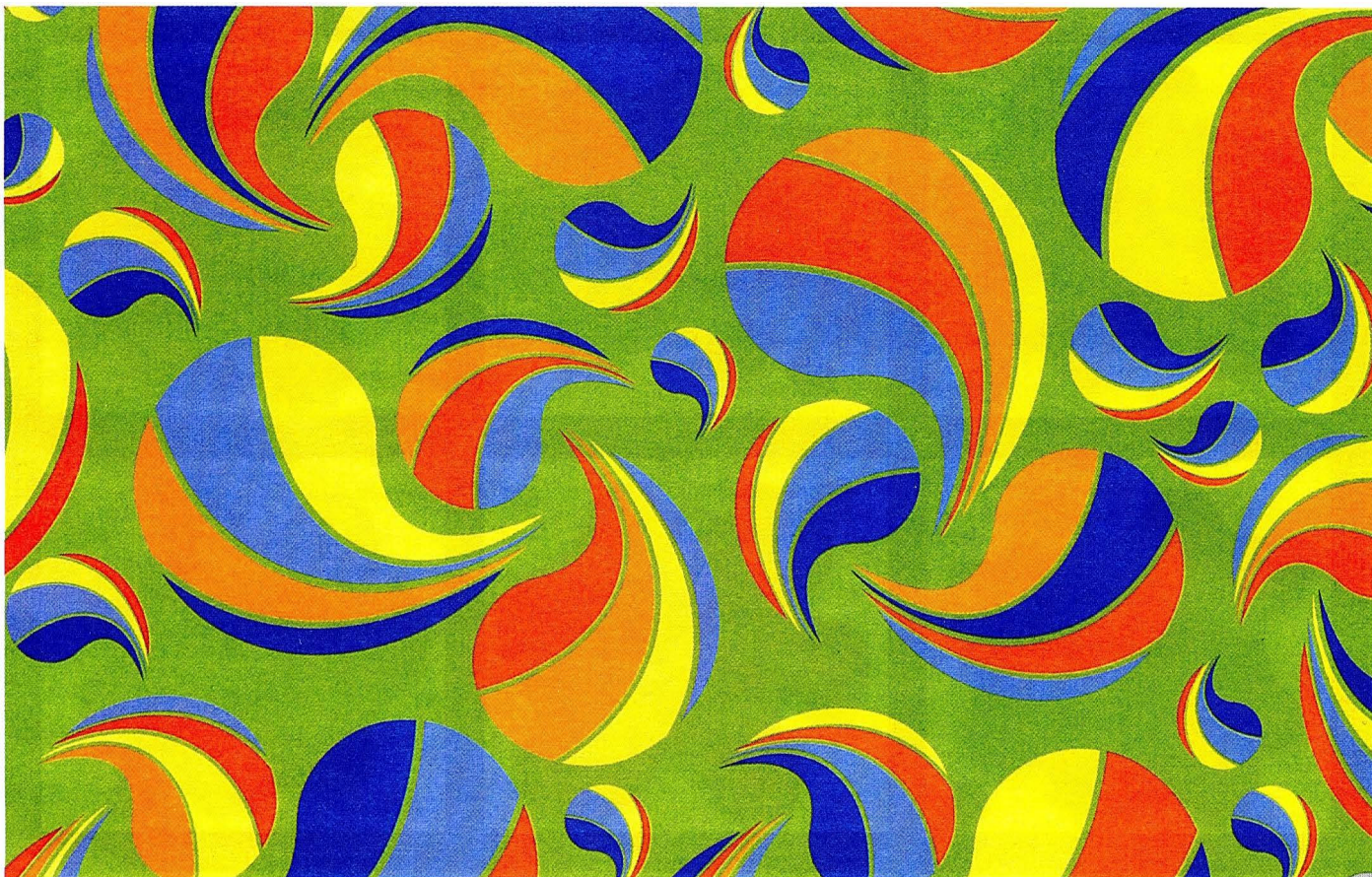

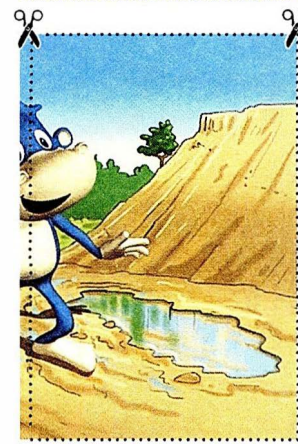
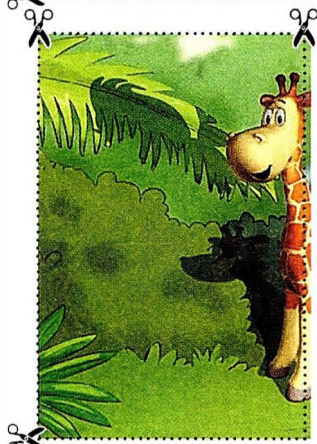
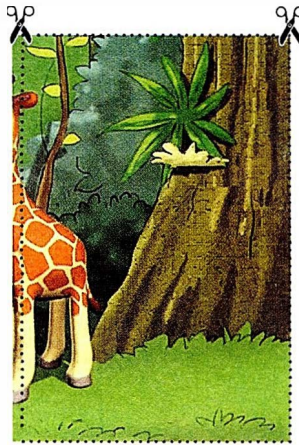
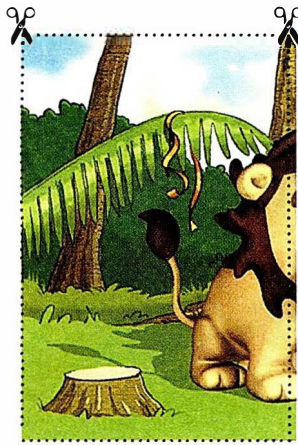
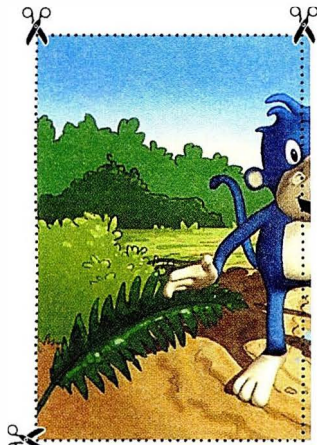

Super Minds

Workbook
Starter

Are you ready to
become one of the Super Minds?

This exciting seven-level course, from a highly experienced author team, enhances your students' thinking skills, improving their memory along with their English.

- 🍌 Develop creativity with visualisation exercises and art and craft activities
- 🍌 Explore social values with lively stories
- 🍌 Encourage cross-curricular thinking with fascinating 'English for school' sections

This Workbook features a page of activities to accompany each page of the Student's Book.

FREE extra resources can be downloaded from
www.cambridge.org/elt/superminds

مرجع زبان ایرانیان

Super Minds Level	CEFR Level	Cambridge ESOL exams
Level 6	A2-B1	Towards Preliminary
Level 5	A2	Flyers/Key
Level 4	A1	Movers
Level 3		
Level 2		Starters
Level 1		
Starter		

Starter

Student's Book with DVD-ROM
Workbook
Teacher's Book
Teacher's Resource Book

Class Audio CDs
Flashcards
Classware and
Interactive DVD-ROM (MP)

Other resources you can use:

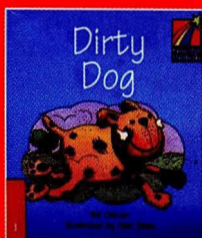

ISBN 978 0 521 00658 3

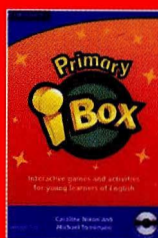

ISBN 978 0 521 51574 0

Includes mini
picture cards for
classroom games and
group activities!



CAMBRIDGE
UNIVERSITY PRESS
www.cambridge.org

مرجع آموزش زبان ایرانیان

www.
IR.com
irLanguage.com

www.irLanguage.com